

VKRIV - DUAL BLOCKB Ρυθμιστική Σφαιρική Βάνα

DUAL BLOCK^B regulating ball valve with female ends for solvent welding, metric series

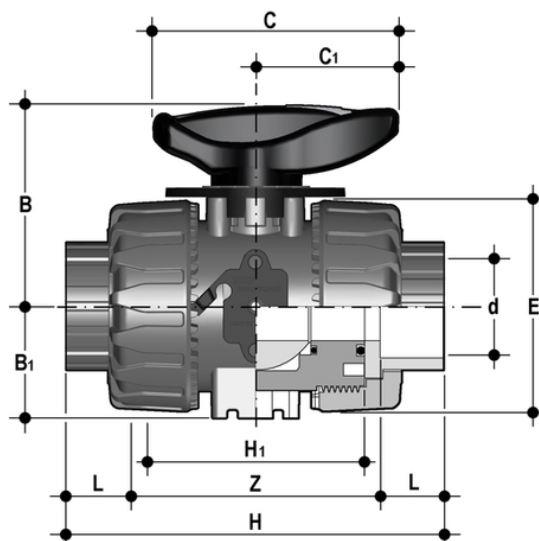

EPDM

Κωδικός προϊόντος	tootiplmage	d	DN	PN	B	B[5:1]	C	C[5:1]	E	H	H[5:1]	L	Z	g
VKRIA016E	-	16	10	16	54	29	67	40	54	103	65	14	75	215
VKRIA020E	-	20	15	16	54	29	67	40	54	103	65	16	71	205
VKRIA025E	-	25	20	16	65	34,5	85	49	65	115	70	19	77	330
VKRIA032E	-	32	25	16	69,5	39	85	49	73	128	78	22	84	438
VKRIA040E	-	40	32	16	82,5	46	108	64	86	146	88	26	94	693
VKRIA050E	-	50	40	16	89	52	108	64	98	164	93	31	102	925
VKRIA063E	-	63	50	16	108	62	134	76	122	199	111	38	123	1577

FKM

Κωδικός προϊόντος	tootiplmage	d	DN	PN	B	B[5:1]	C	C[5:1]	E	H	H[5:1]	L	Z	g
VKRIA016F	-	16	10	16	54	29	67	40	54	103	65	14	75	215
VKRIA020F	-	20	15	16	54	29	67	40	54	103	65	16	71	205
VKRIA025F	-	25	20	16	65	34,5	85	49	65	115	70	19	77	330
VKRIA032F	-	32	25	16	69,5	39	85	49	73	128	78	22	84	438
VKRIA040F	-	40	32	16	82,5	46	108	64	86	146	88	26	94	693
VKRIA050F	-	50	40	16	89	52	108	64	98	164	93	31	102	925
VKRIA063F	-	63	50	16	108	62	134	76	122	199	111	38	123	1577

VKRIV - DUAL BLOCKB Ρυθμιστική Σφαιρική Βάνα

- HIPVC ergonomic multifunctional handle with **position indicator** and tool to adjust the ball seat carrier
- Flow direction and opening angle indication plate with **graduated scale with 5B° detail** for clear and accurate readings
- 90B° operating angle that permits **the use of standard** quarter turn **actuators**
- The patented ball design provides **linear flow adjustment** throughout its range of operation even when the valve is open just a few degrees and guarantees minimum pressure drops
- Patented **DUAL BLOCKB** system: prevents union nuts from loosening even under extreme operating conditions: e.g. vibration or thermal expansion

- Connection system for solvent weld, threaded and flanged joints
- Patented **SEAT STOPB** ball carrier system that lets you micro-adjust seals and minimise the axial force effect
- Easy radial dismounting allowing quick replacement of O-rings and ball seats without any need for tools
- **PN16 True Union valve body** made for rigid PVC-U injection moulding equipped with built-in bores for actuation. ISO 9393 compliant test requisites
- Option of dismounting downstream pipes with the valve in the closed position
- High surface finish stem with double O-Ring and double connection key to ball
- **Integrated bracket** for valve anchoring
- Ball seat carrier can be adjusted using the **Easytorque adjustment kit**
- Actuation option: version with electric modulating actuator with 4-20 mA / 0-10 V inlet and 4-20 mA / 0-10 V outlet to monitor the position
- Valve suitable for carrying fluids that are clean and free of suspended particles