

UAN

Αντάπτορας HD-PE/Brass με αρσενικό σπείρωμα

Compact fitting, spigot allows for assembly irrespective of its position and homogenous fusion joint with all suitable FRIALEN fittings. Brass side permanently and tightly connected with PE spigot. Cannot be released or rotated.

Other thread sizes on request

Lead-free version available on request

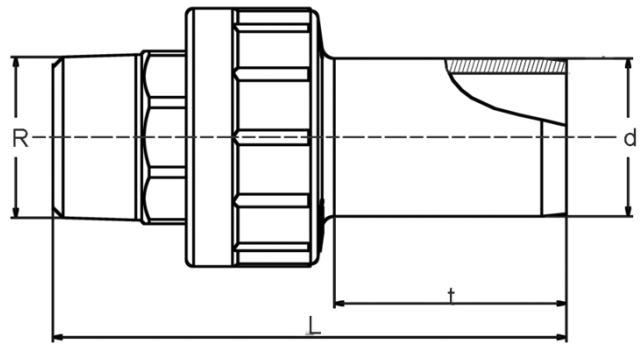

PE 100 SDR 11

Maximum working pressure 16 bar (water)/5 bar (gas)



Κωδικός προϊόντος	d	BX	PU	R	L	t	SW	Weight kg
616604	20	70	4200	1/2"	94	41	22	0,100
616605	25	60	3600	3/4"	92	44	28	0,150
616152	32	30	1800	1"	104	47	35	0,240
616153	40	20	1200	1 1/4"	121	56	44	0,400
616154	50	16	960	1 1/2"	123	57	50	0,520
616610	63	9	540	1 1/2"	136	63	50	0,620
616155	63	9	540	2"	140	63	62	0,730
616612	75	10	300	2 1/2"	155	70	77	1,200
616613	90	6	180	3"	172	78	90	1,600
616614	110	4	120	4"	200	87	115	2,900
616664	125	4	120	4"	200	92	115	2,950

Please observe the marking directly at the product, which is mandatory.

DVGW-Registration Nos.

DW-7511CR0155

DG-7521CR0172

The brass-male thread is made from material CW612N or CW617N.

UAN

Αντάπτορας **HD-PE/Brass** με αρσενικό σπείρωμα

Other brass materials on request.

UAN

Αντάπτορας HD-PE/Brass με αρσενικό σπείρωμα

Areas of Application

The FRIALEN Universal Adapter UAN serves to connect metal construction parts which have a screwed connection e.g. valves with an HD-PE connection pipe. Suitable for gas and water supply or for industrial applications. The version with PE spigot end allows for assembly regardless of location and the homogenous fusion connection with all suitable FRIALEN fittings (exception of FRIALONG- and FRIASTOPP-Long couplers).

The threaded joint is according ISO 7-1.

Assembly Instructions

Usually the screw connection needs to be assembled first as assembly related torsion forces should not bear down on the connected PE pipe. The tightening forces must be introduced via the specially designed wrench area.

The fusion of the PE spigot end with a FRIALEN coupler takes place by using FRIALEN fusion process – leakproof and longitudinally strong.

The installation is according to the general installation instruction (see "Transition Fittings with threaded connection" in "Assembly Instructions" for "FRIALEN-Safety Fittings for house connections and distribution pipes up to d 225"). This involves removing the oxide layer and cleaning the pipe ends.

Good reasons for using the FRIALEN-Universal Adapter UAN:

PE 100 spigot end – quality controlled

Tested and quality controlled brass quality

Assembly regardless of location, high degree of flexibility due to separate fusion of PE spigot end

May be used with all FRIALEN fittings of identical dimensions (exception of FRIALONG- and FRIASTOPP-Long couplers)

Universal combination option with the FRIALEN range

HD-PE side with spigot end for processing without holding device, designed for FRIALEN couplers

Pull-proof connection

Brass side tightly connected with PE spigot end, safe from distortion

Compact construction

Additional barcode for tracing back the fitting (Traceability-Coding)

Oxidic layer may be removed from PE spigot end using scraper tools