

ABS 45

Γωνίες λυμάτων νερού 45° (spigot εξαρτήματα)

HD-PE fitting for use with FRIAFIT sewage sleeve AM without holding devices.

Pipe colour black with bright inner surface (according to availability)

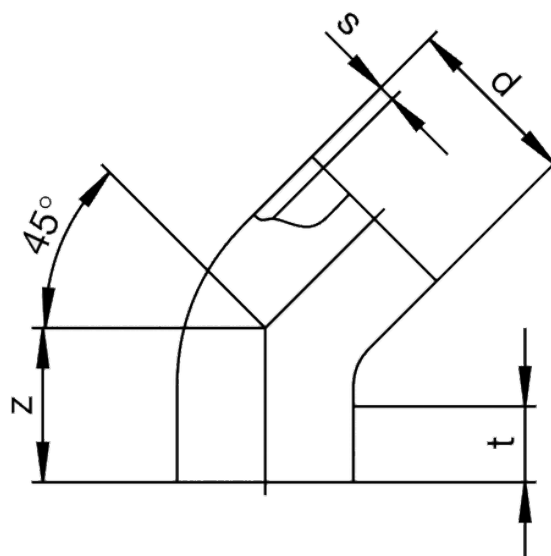

PE 80/PE 100

Maximum testing pressure 0.5 bar in accordance to DIN EN 1610

Κωδικός προϊόντος	d	BX	t	Z	s	Weight kg
681201	160	1	170	280	9,1	2,780
681203	200	1	250	349	11,4	5,000
681204	225	1	250	380	12,8	6,870
681205	250	1	250	411	14,2	9,210
681206	280	1	300	448	15,9	12,500
681207	315	1	300	491	17,9	17,400
681208	355	1	300	541	20,1	24,300