

VKDIM - DUAL BLOCKB 2-way

Βάνα Σφαιρική

Dual Block^B 2-way ball valve with female ends for socket welding, metric series

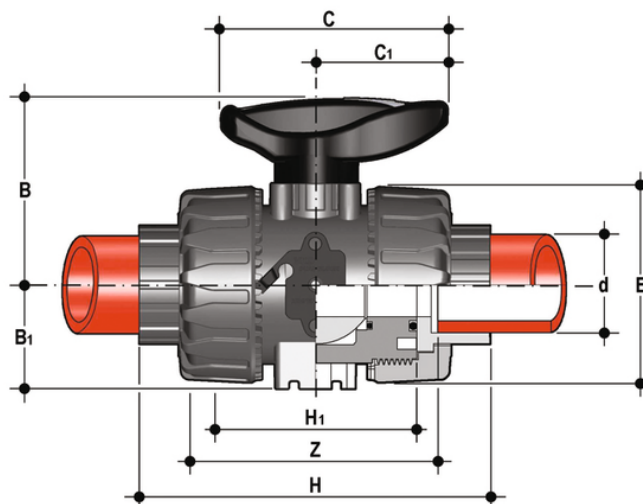

EPDM

Κωδικός προϊόντος	d	DN	PN	B	B[5:1]	C	C[5:1]	E	H	H[5:1]	Z	g
VKDIM016E	16	10	10	54	29	67	40	54	102	65	74,5	150
VKDIM020E	20	15	10	54	29	67	40	54	102	65	73	145
VKDIM025E	25	20	10	65	34,5	85	49	65	114	70	82	218
VKDIM032E	32	25	10	69,5	39	85	49	73	126	78	90	298
VKDIM040E	40	32	10	82,5	46	108	64	86	141	88	100	480
VKDIM050E	50	40	10	89	52	108	64	98	164	93	117	682
VKDIM063E	63	50	10	108	62	134	76	122	199	111	144	1166

EPDM

Κωδικός προϊόντος	d	DN	PN	B	B[5:1]	C	C[5:1]	E	H	H[5:1]	Z	g
VKDIM016EOLF	16	10	10	54	29	67	40	54	102	65	74,5	150
VKDIM020EOLF	20	15	10	54	29	67	40	54	102	65	73	145
VKDIM025EOLF	25	20	10	65	34,5	85	49	65	114	70	82	218
VKDIM032EOLF	32	25	10	69,5	39	85	49	73	126	78	90	298
VKDIM040EOLF	40	32	10	82,5	46	108	64	86	141	88	100	480
VKDIM050EOLF	50	40	10	89	52	108	64	98	164	93	117	682
VKDIM063EOLF	63	50	10	108	62	134	76	122	199	111	144	1166

VKDIM - DUAL BLOCKB 2-way

Βάνα Σφαιρική

EPDM

Κωδικός προϊόντος	d	DN	PN	B	B[5:1]	C	C[5:1]	E	H	H[5:1]	Z	g
VKDIM016E0SF	16	10	10	54	29	67	40	54	102	65	74,5	150
VKDIM020E0SF	20	15	10	54	29	67	40	54	102	65	73	145
VKDIM025E0SF	25	20	10	65	34,5	85	49	65	114	70	82	218
VKDIM032E0SF	32	25	10	69,5	39	85	49	73	126	78	90	298
VKDIM040E0SF	40	32	10	82,5	46	108	64	86	141	88	100	480
VKDIM050E0SF	50	40	10	89	52	108	64	98	164	93	117	682
VKDIM063E0SF	63	50	10	108	62	134	76	122	199	111	144	1166

FKM

Κωδικός προϊόντος	d	DN	PN	B	B[5:1]	C	C[5:1]	E	H	H[5:1]	Z	g
VKDIM016F	16	10	10	54	29	67	40	54	102	65	74,5	150
VKDIM020F	20	15	10	54	29	67	40	54	102	65	73	145
VKDIM025F	25	20	10	65	34,5	85	49	65	114	70	82	218
VKDIM032F	32	25	10	69,5	39	85	49	73	126	78	90	298
VKDIM040F	40	32	10	82,5	46	108	64	86	141	88	100	480
VKDIM050F	50	40	10	89	52	108	64	98	164	93	117	682
VKDIM063F	63	50	10	108	62	134	76	122	199	111	144	1166

FKM

Κωδικός προϊόντος	d	DN	PN	B	B[5:1]	C	C[5:1]	E	H	H[5:1]	Z	g
VKDIM016FOLF	16	10	10	54	29	67	40	54	102	65	74,5	150
VKDIM020FOLF	20	15	10	54	29	67	40	54	102	65	73	145
VKDIM025FOLF	25	20	10	65	34,5	85	49	65	114	70	82	218
VKDIM032FOLF	32	25	10	69,5	39	85	49	73	126	78	90	298
VKDIM040FOLF	40	32	10	82,5	46	108	64	86	141	88	100	480
VKDIM050FOLF	50	40	10	89	52	108	64	98	164	93	117	682
VKDIM063FOLF	63	50	10	108	62	134	76	122	199	111	144	1166

FKM

Κωδικός προϊόντος	d	DN	PN	B	B[5:1]	C	C[5:1]	E	H	H[5:1]	Z	g
VKDIM016FOSF	16	10	10	54	29	67	40	54	102	65	74,5	150
VKDIM020FOSF	20	15	10	54	29	67	40	54	102	65	73	145
VKDIM025FOSF	25	20	10	65	34,5	85	49	65	114	70	82	218
VKDIM032FOSF	32	25	10	69,5	39	85	49	73	126	78	90	298

VKDIM - DUAL BLOCKB 2-way

Βάνα Σφαιρική

Κωδικός Προϊόντος	d	DN	PN	B	B[5:1]	C	C[5:1]	E	H	H[5:1]	Z	g
VKDIM040FOSF	40	32	10	82,5	46	108	64	86	141	88	100	480
VKDIM050FOSF	50	40	10	89	52	108	64	98	164	93	117	682
VKDIM063FOSF	63	50	10	108	62	134	76	122	199	111	144	1166

VKDIM - DUAL BLOCKB 2-way

Βάνα Σφαιρική

- Ergonomic HIPVC handle equipped with **removable tool to adjust the ball seat carrier**.
- **Handle lock 0B°- 90B°** SHKD (available as an accessory) ergonomically operable during service and padlockable
- Robust **integrated bracket for valve anchoring**, for easy and quick automation even after valve installation on the system via the Power Quick module (optional)
- **DUAL BLOCKB** patented lock system that ensures union nut tightening hold even in severe conditions such as vibrations or heat dilation
- Machined high surface finish ball that guarantees a smooth operation and increased reliability

- Connection system for solvent weld, threaded and flanged joints
- Patented **SEAT STOPB** ball carrier system that lets you micro-adjust ball seats and minimise the axial force effect
- Easy radial dismounting allowing quick replacement of O-rings and ball seats without any need for tools
- **PN16 True Union valve body** made for rigid PVC-U injection moulding equipped with built-in bores for actuation. ISO 9393 compliant test requisites
- Option of dismounting downstream pipes with the valve in the closed position
- Floating **full bore ball** with high surface finish
- **Integrated bracket** for valve anchoring
- Ball seat carriers can be adjusted using the **Easytorque adjustment kit**
- Possibility to have handle with integrated LSQT limit micro switch, even as a retrofit in existing installations