

VKDIF/SHX - DUAL BLOCK^B 2-way

Βάνα Σφαιρική

DUAL BLOCK^B 2-way ball valve with handle lock and STAINLESS steel threaded inserts for fastening, with female ends for butt welding, metric series

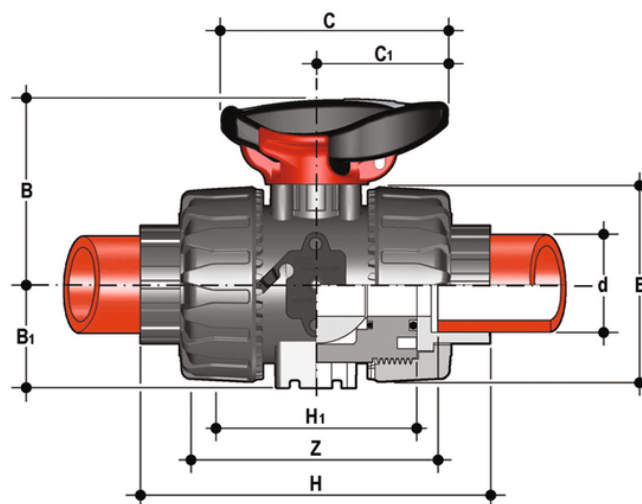

Κωδικός προϊόντος	tooltiplmage	d	DN	PN	B	B[5:1]	C	C[5:1]	E	H	H[5:1]	Z	g
VKDIFSHX016F	-	16	10	16	54	29	67	40	54	102	65	74,5	291
VKDIFSHX020F	-	20	15	16	54	29	67	40	54	102	65	73	272
VKDIFSHX025F	-	25	20	16	65	34,5	85	49	65	114	70	82	445
VKDIFSHX032F	-	32	25	16	69,5	39	85	49	73	126	78	90	584
VKDIFSHX040F	-	40	32	16	82,5	46	108	64	86	141	88	100	938
VKDIFSHX050F	-	50	40	16	89	52	108	64	98	164	93	117	1242
VKDIFSHX063F	-	63	50	16	108	62	134	76	122	199	111	144	2187

VKDIF/SHX - DUAL BLOCKB 2-way

Βάνα Σφαιρική

- Ergonomic HIPVC handle equipped with **removable tool to adjust the ball seat carrier**.
- **Handle lock 0B°- 90B°** SHKD (available as an accessory) ergonomically operable during service and padlockable
- Robust **integrated bracket for valve anchoring**, for easy and quick automation even after valve installation on the system via the Power Quick module (optional)
- **DUAL BLOCKB** patented lock system that ensures union nut tightening hold even in severe conditions such as vibrations or heat dilation
- Machined high surface finish ball that guarantees a smooth operation and increased reliability

- Connection system for solvent weld, threaded and flanged joints
- Patented **SEAT STOPB** ball carrier system that lets you micro-adjust ball seats and minimise the axial force effect
- Easy radial dismounting allowing quick replacement of O-rings and ball seats without any need for tools
- **PN16 True Union valve body** made for rigid PVC-U injection moulding equipped with built-in bores for actuation. ISO 9393 compliant test requisites
- Option of dismounting downstream pipes with the valve in the closed position
- Floating **full bore ball** with high surface finish
- **Integrated bracket** for valve anchoring
- Ball seat carriers can be adjusted using the **Easytorque adjustment kit**
- Possibility to have handle with integrated LSQT limit micro switch, even as a retrofit in existing installations