

VKDIM/SHX - DUAL BLOCK^B 2-way Βάνα Σφαιρική

Dual Block^B 2-way ball valve with handle lock and STAINLESS steel threaded inserts with female ends for socket welding, metric series

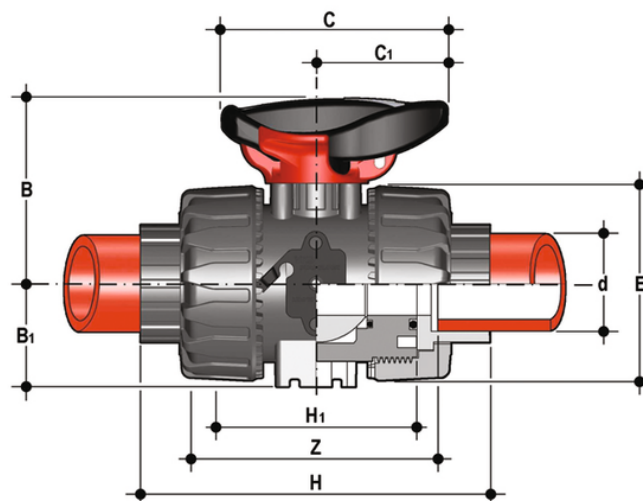

EPDM

Κωδικός προϊόντος	d	DN	PN	B	B[5:1]	C	C[5:1]	E	H	H[5:1]	Z	g
VKDIMSHX016E	16	10	10	54	29	67	40	54	102	65	74,5	160
VKDIMSHX020E	20	15	10	54	29	67	40	54	102	65	73	155
VKDIMSHX025E	25	20	10	65	34,5	85	49	65	114	70	82	228
VKDIMSHX032E	32	25	10	69,5	39	85	49	73	126	78	90	308
VKDIMSHX040E	40	32	10	82,5	46	108	64	86	141	88	100	490
VKDIMSHX050E	50	40	10	89	52	108	64	98	164	93	117	692
VKDIMSHX063E	63	50	10	108	62	134	76	122	199	111	144	1176

FKM

Κωδικός προϊόντος	d	DN	PN	B	B[5:1]	C	C[5:1]	E	H	H[5:1]	Z	g
VKDIMSHX016F	16	10	10	54	29	67	40	54	102	65	74,5	160
VKDIMSHX020F	20	15	10	54	29	67	40	54	102	65	73	155
VKDIMSHX025F	25	20	10	65	34,5	85	49	65	114	70	82	228
VKDIMSHX032F	32	25	10	69,5	39	85	49	73	126	78	90	308
VKDIMSHX040F	40	32	10	82,5	46	108	64	86	141	88	100	490
VKDIMSHX050F	50	40	10	89	52	108	64	98	164	93	117	692
VKDIMSHX063F	63	50	10	108	62	134	76	122	199	111	144	1176

VKDIM/SHX - DUAL BLOCKB 2- way Βάνα Σφαιρική

- Ergonomic HIPVC handle equipped with **removable tool to adjust the ball seat carrier**.
- **Handle lock 0B°- 90B°** SHKD (available as an accessory) ergonomically operable during service and padlockable
- Robust **integrated bracket for valve anchoring**, for easy and quick automation even after valve installation on the system via the Power Quick module (optional)
- **DUAL BLOCKB** patented lock system that ensures union nut tightening hold even in severe conditions such as vibrations or heat dilation
- Machined high surface finish ball that guarantees a smooth operation and increased reliability

- Connection system for solvent weld, threaded and flanged joints
- Patented **SEAT STOPB** ball carrier system that lets you micro-adjust ball seats and minimise the axial force effect
- Easy radial dismounting allowing quick replacement of O-rings and ball seats without any need for tools
- **PN16 True Union valve body** made for rigid PVC-U injection moulding equipped with built-in bores for actuation. ISO 9393 compliant test requisites
- Option of dismounting downstream pipes with the valve in the closed position
- Floating **full bore ball** with high surface finish
- **Integrated bracket** for valve anchoring
- Ball seat carriers can be adjusted using the **Easytorque adjustment kit**
- Possibility to have handle with integrated LSQT limit micro switch, even as a retrofit in existing installations