

LKDIM - DUAL BLOCKB 3-way

Σφαιρική Βάνα

DUAL BLOCK^B 3-way ball valve with metric plain socket ends for socket welding, - L bore.

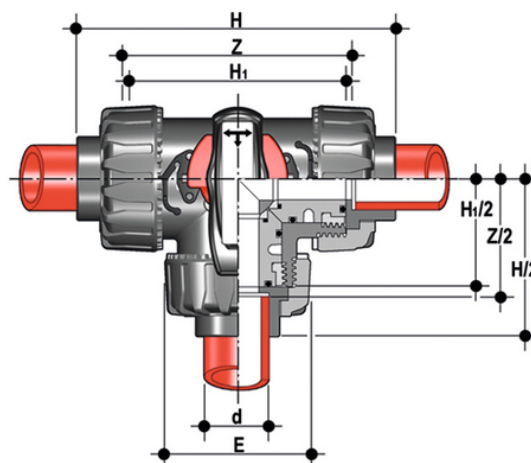

EPDM

Κωδικός Προϊόντος	tooltiplmage	d	DN	PN	E	H	H[5:1]	Z	g
LKDIM020E	-	20	15	10	54	117	80	88	195
LKDIM025E	-	25	20	10	65	144	100	112	350
LKDIM032E	-	32	25	10	73	158	110	122	505
LKDIM040E	-	40	32	10	86	184	131	143	820
LKDIM050E	-	50	40	10	98	219	148	172	1070
LKDIM063E	-	63	50	10	122	267	179	212	1795

EPDM

Κωδικός Προϊόντος	tooltiplmage	d	DN	PN	E	H	H[5:1]	Z	g
LKDIM020EOLF	-	20	15	10	54	117	80	88	195
LKDIM025EOLF	-	25	20	10	65	144	100	112	350
LKDIM032EOLF	-	32	25	10	73	158	110	122	505
LKDIM040EOLF	-	40	32	10	86	184	131	143	820
LKDIM050EOLF	-	50	40	10	98	219	148	172	1070
LKDIM063EOLF	-	63	50	10	122	267	179	212	1795

EPDM

LKDIM - DUAL BLOCKB 3-way

Σφαιρική Βάνα

Κωδικός Προϊόντος	tooltiplmage	d	DN	PN	E	H	H[5:1]	Z	g
LKDIM020E0SF	-	20	15	10	54	117	80	88	195
LKDIM025E0SF	-	25	20	10	65	144	100	112	350
LKDIM032E0SF	-	32	25	10	73	158	110	122	505
LKDIM040E0SF	-	40	32	10	86	184	131	143	820
LKDIM050E0SF	-	50	40	10	98	219	148	172	1070
LKDIM063E0SF	-	63	50	10	122	267	179	212	1795

FKM

Κωδικός Προϊόντος	tooltiplmage	d	DN	PN	E	H	H[5:1]	Z	g
LKDIM020F	-	20	15	10	54	117	80	88	195
LKDIM025F	-	25	20	10	65	144	100	112	350
LKDIM032F	-	32	25	10	73	158	110	122	505
LKDIM040F	-	40	32	10	86	184	131	143	820
LKDIM050F	-	50	40	10	98	219	148	172	1070
LKDIM063F	-	63	50	10	122	267	179	212	1795

FKM

Κωδικός Προϊόντος	tooltiplmage	d	DN	PN	E	H	H[5:1]	Z	g
LKDIM020FOLF	-	20	15	10	54	117	80	88	195
LKDIM025FOLF	-	25	20	10	65	144	100	112	350
LKDIM032FOLF	-	32	25	10	73	158	110	122	505
LKDIM040FOLF	-	40	32	10	86	184	131	143	820
LKDIM050FOLF	-	50	40	10	98	219	148	172	1070
LKDIM063FOLF	-	63	50	10	122	267	179	212	1795

FKM

Κωδικός προϊόντος	tooltiplmage	d	DN	PN	E	H	H[5:1]	Z	g
LKDIM020F0SF	-	20	15	10	54	117	80	88	195
LKDIM025F0SF	-	25	20	10	65	144	100	112	350
LKDIM032F0SF	-	32	25	10	73	158	110	122	505
LKDIM040F0SF	-	40	32	10	86	184	131	143	820
LKDIM050F0SF	-	50	40	10	98	219	148	172	1070
LKDIM063F0SF	-	63	50	10	122	267	179	212	1795

LKDIM - DUAL BLOCKB 3-way

Σφαιρική Βάνα

- Ergonomic HIPVC handle equipped with removable tool to adjust the ball seat carrier. Possibility of installing the **LTKD stroke limiter** (available as an accessory) that permits ball and handle rotation only for set opening and closing angles at 90B° or 180B°
- **Handle lock 0B°- 90B° SHKD** (available as an accessory) ergonomically operable during service and padlockable
- **DUAL BLOCKB** patented lock system that ensures union nut tightening hold even in severe conditions such as vibrations or heat dilation
- **Ball shutter** high surface finish with floating type full passage with **T or L port**
- **4 PTFE ball seat system** that compensates axial force guaranteeing optimal manageability and long working life

- Connection system for weld and threaded joints
- Patented **SEAT STOPB** ball seat carrier system that lets you micro-adjust ball seats and minimise axial force effects
- Easy radial disassembly allowing quick replacement of O-rings and ball seats without any need for tools
- PN10 **True Union valve body** made for PP-H injection moulding equipped with built-in bores for actuation. ISO 9393 compliant test requisites
- Option of disassembling downstream pipes with the valve in the closed position
- High surface finish stem with double O-Ring and double groove ball connection, equipped with **optical position indicator** for correct handle installation
- **Integrated bracket** for valve anchoring
- Possibility of installing pneumatic and/or electric actuators thanks to the robust integrated bracket for valve anchoring for easy and quick automation using the Power Quick module (optional)
- Possibility to have handle with integrated LSQT limit micro switch, even as a retrofit in existing installations