

VKDIV/SHX - DUAL BLOCK^B 2-way

Βάνα Σφαιρική

DUAL BLOCK^B 2-way ball valve with handle lock and STAINLESS steel threaded inserts with female ends for solvent welding, metric series

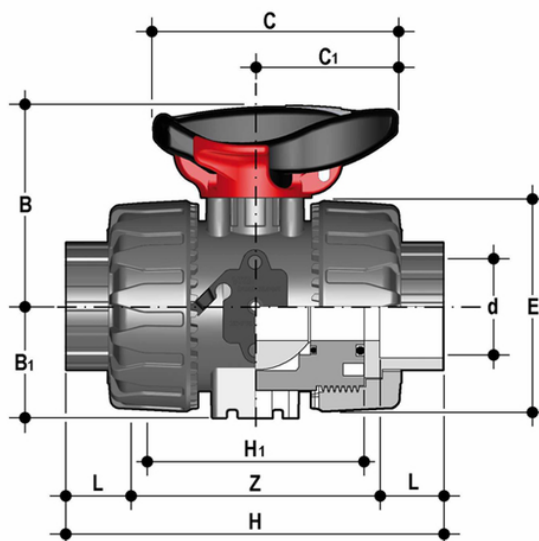

EPDM

Κωδικός προϊόντος	tooliplmage	d	DN	PN	B	B[5:1]	C	C[5:1]	E	H	H[5:1]	L	Z	g
VKDIVSHX016E	-	16	10	16	54	29	67	40	54	103	65	14	75	225
VKDIVSHX020E	-	20	15	16	54	29	67	40	54	103	65	16	71	215
VKDIVSHX025E	-	25	20	16	65	34,5	85	49	65	115	70	19	77	340
VKDIVSHX032E	-	32	25	16	69,5	39	85	49	73	128	78	22	84	448
VKDIVSHX040E	-	40	32	16	82,5	46	108	64	86	146	88	26	94	703
VKDIVSHX050E	-	50	40	16	89	52	108	64	98	164	93	31	102	935
VKDIVSHX063E	-	63	50	16	108	62	134	76	122	199	111	38	123	1587

FKM

Κωδικός προϊόντος	tooliplmage	d	DN	PN	B	B[5:1]	C	C[5:1]	E	H	H[5:1]	L	Z	g
VKDIVSHX016F	-	16	10	16	54	29	67	40	54	103	65	14	75	225
VKDIVSHX020F	-	20	15	16	54	29	67	40	54	103	65	16	71	215
VKDIVSHX025F	-	25	20	16	65	34,5	85	49	65	115	70	19	77	340
VKDIVSHX032F	-	32	25	16	69,5	39	85	49	73	128	78	22	84	448
VKDIVSHX040F	-	40	32	16	82,5	46	108	64	86	146	88	26	94	703
VKDIVSHX050F	-	50	40	16	89	52	108	64	98	164	93	31	102	935
VKDIVSHX063F	-	63	50	16	108	62	134	76	122	199	111	38	123	1587

VKDIV/SHX – DUAL BLOCKB 2-way

Βάνα Σφαιρική

- Ergonomic HIPVC handle equipped with **removable tool to adjust the ball seat carrier**.
- **Handle lock 0B°- 90B°** SHKD (available as an accessory) ergonomically operable during service and padlockable
- Robust **integrated bracket for valve anchoring**, for easy and quick automation even after valve installation on the system via the Power Quick module (optional)
- **DUAL BLOCKB** patented lock system that ensures union nut tightening hold even in severe conditions such as vibrations or heat dilation
- Machined high surface finish ball that guarantees a smooth operation and increased reliability

- Connection system for solvent weld, threaded and flanged joints
- Patented **SEAT STOPB** ball carrier system that lets you micro-adjust ball seats and minimise the axial force effect
- Easy radial dismounting allowing quick replacement of O-rings and ball seats without any need for tools
- **PN16 True Union valve body** made for rigid PVC-U injection moulding equipped with built-in bores for actuation. ISO 9393 compliant test requisites
- Option of dismounting downstream pipes with the valve in the closed position
- Floating **full bore ball** with high surface finish
- **Integrated bracket** for valve anchoring
- Ball seat carriers can be adjusted using the **Easytorque adjustment kit**
- Possibility to have handle with integrated LSQT limit micro switch, even as a retrofit in existing installations