

LKDIC - DUAL BLOCKB 3-WAY

Βάνα Σφαιρική

DUAL BLOCK^B 3-way ball valve with metric plain socket ends for solvent welding, L bore.

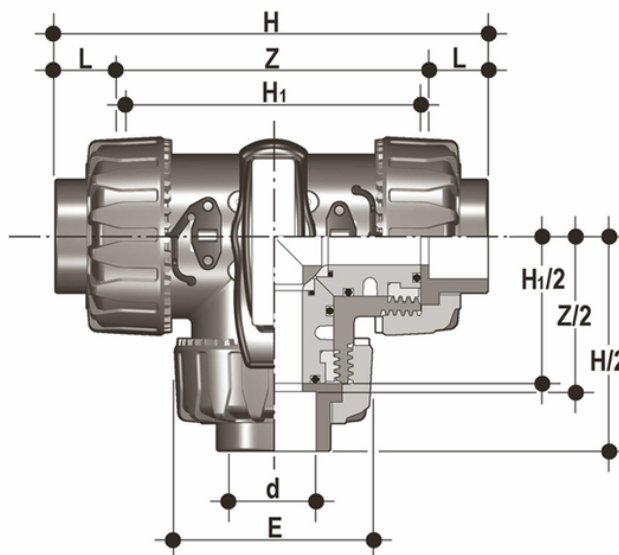

EPDM

Κωδικός προϊόντος	tooliplmage	d	DN	PN	E	H	H[5:1]	L	Z	g
LKDIC016E	-	16	10	16	54	118	80	14	90	310
LKDIC020E	-	20	15	16	54	118	80	16	86	310
LKDIC025E	-	25	20	16	65	145	100	19	107	550
LKDIC032E	-	32	25	16	73	160	110	22	116	790
LKDIC040E	-	40	32	16	86	188.5	131	26	136.5	1275
LKDIC050E	-	50	40	16	98	219	148	31	157	1660
LKDIC063E	-	63	50	16	122	266.5	179	38	190.5	2800

EPDM

Κωδικός προϊόντος	tooliplmage	d	DN	PN	E	H	H[5:1]	L	Z	g
LKDIC016E0LF	-	16	10	16	54	118	80	14	90	310
LKDIC020E0LF	-	20	15	16	54	118	80	16	86	310
LKDIC025E0LF	-	25	20	16	65	145	100	19	107	550
LKDIC032E0LF	-	32	25	16	73	160	110	22	116	790
LKDIC040E0LF	-	40	32	16	86	188.5	131	26	136.5	1275
LKDIC050E0LF	-	50	40	16	98	219	148	31	157	1660
LKDIC063E0LF	-	63	50	16	122	266.5	179	38	190.5	2800

LKDIC - DUAL BLOCK B 3-WAY

Βάνα Σφαιρική

EPDM

Κωδικός προϊόντος	tooltiplmage	d	DN	PN	E	H	H[5:1]	L	Z	g
LKDIC016E0SF	-	16	10	16	54	118	80	14	90	310
LKDIC020E0SF	-	20	15	16	54	118	80	16	86	310
LKDIC025E0SF	-	25	20	16	65	145	100	19	107	550
LKDIC032E0SF	-	32	25	16	73	160	110	22	116	790
LKDIC040E0SF	-	40	32	16	86	188.5	131	26	136.5	1275
LKDIC050E0SF	-	50	40	16	98	219	148	31	157	1660
LKDIC063E0SF	-	63	50	16	122	266.5	179	38	190.5	2800

FKM

Κωδικός προϊόντος	tooltiplmage
LKDIC016F	-
LKDIC020F	-
LKDIC025F	-
LKDIC032F	-
LKDIC040F	-
LKDIC050F	-
LKDIC063F	-

FKM

Κωδικός προϊόντος	tooltiplmage
LKDIC016FOLF	-
LKDIC020FOLF	-
LKDIC025FOLF	-
LKDIC032FOLF	-
LKDIC040FOLF	-
LKDIC050FOLF	-
LKDIC063FOLF	-

FKM

Κωδικός προϊόντος	tooltiplmage
LKDIC016F0SF	-
LKDIC020F0SF	-
LKDIC025F0SF	-
LKDIC032F0SF	-



LKDIC - DUAL BLOCKB 3-WAY

Βάνα Σφαιρική

Κωδικός Προϊόντος	tooltipImage
LKDIC040F0SF	-
LKDIC050F0SF	-
LKDIC063F0SF	-

LKDIC - DUAL BLOCKB 3-WAY

Βάνα Σφαιρική

- Ergonomic HIPVC handle equipped with removable tool to adjust the ball seat carrier. Possibility of installing the **LTKD stroke limiter** (available as an accessory) that permits ball and handle rotation only for set opening and closing angles at 90B° or 180B°
- **Handle lock 0B°- 90B° SHKD** (available as an accessory) ergonomically operable during service and padlockable
- **DUAL BLOCKB** patented lock system that ensures union nut tightening hold even in severe conditions such as vibrations or heat dilation
- **Ball shutter** high surface finish with floating type full passage with **T or L port**
- **4 PTFE ball seat system** that compensates axial force guaranteeing optimal manageability and long working life

- Connection system for solvent weld, threaded and flanged joints
- Patented **SEAT STOPB** ball carrier system that lets you micro-adjust ball seats and minimise axial force effects
- Easy radial dismounting allowing quick replacement of O-rings and ball seats without any need for tools
- **PN16 True Union valve body** made for rigid PVC-U injection moulding equipped with built-in bores for actuation. ISO 9393 compliant test requisites
- Option of dismounting downstream pipes with the valve in the closed position
- High surface finish stem with double O-Ring and double connection key to the ball, equipped with **visual ball position indicator** for correct handle installation
- **Integrated bracket** for valve anchoring
- Possibility of installing pneumatic and/or electric actuators thanks to the robust anchor tower for easy and quick automation using the **Power Quick module** (optional)
- Possibility to have handle with integrated LSQT limit micro switch, even as a retrofit in existing installations