

# VKDIM - DUAL BLOCKB 2-way

## Βάνα Σφαιρική

DUAL BLOCK<sup>B</sup> 2-way ball valve with female ends for socket welding, metric series

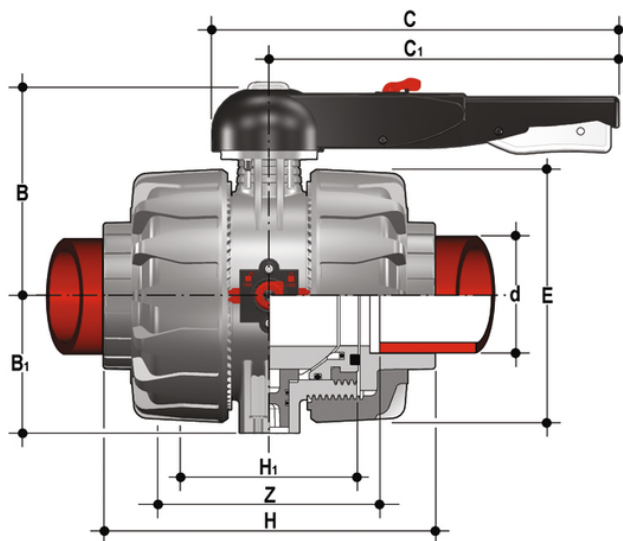

### EPDM

Κωδικός προϊόντος	d	DN	PN	B	B[5:1]	C	C[5:1]	E	H	H[5:1]	L	Z	g
VKDIM075E	75	65	10	164	87	225	175	162	213	133	30	153	3090
VKDIM090E	90	80	10	177	105	327	272	202	239	149	33	173	5080
VKDIM110E	110	100	10	195	129	385	330	236	268	167	34,5	199	7725

### EPDM

Κωδικός προϊόντος	d	DN	PN	B	B[5:1]	C	C[5:1]	E	H	H[5:1]	L	Z	g
VKDIM075E0SF	75	65	10	164	87	225	175	162	213	133	30	153	3090
VKDIM090E0SF	90	80	10	177	105	327	272	202	239	149	33	173	5080
VKDIM110E0SF	110	100	10	195	129	385	330	236	268	167	34,5	199	7725

### FKM

Κωδικός προϊόντος	d	DN	PN	B	B[5:1]	C	C[5:1]	E	H	H[5:1]	L	Z	g
VKDIM075F	75	65	10	164	87	225	175	162	213	133	30	153	3090
VKDIM090F	90	80	10	177	105	327	272	202	239	149	33	173	5080
VKDIM110F	110	100	10	195	129	385	330	236	268	167	34,5	199	7725

### FKM

# VKDIM - DUAL BLOCKB 2-way

## Βάνα Σφαιρική

Κωδικός Προϊόντος	d	DN	PN	B	B[5:1]	C	C[5:1]	E	H	H[5:1]	L	Z	g
VKDIM075FOSF	75	65	10	164	87	225	175	162	213	133	30	153	3090
VKDIM090FOSF	90	80	10	177	105	327	272	202	239	149	33	173	5080
VKDIM110FOSF	110	100	10	195	129	385	330	236	268	167	34,5	199	7725

# VKDIM - DUAL BLOCKB 2-way

## Βάνα Σφαιρική

- HIPVC ergonomic multifunctional handle for quick operation, **lock and graduated adjustment in 10 positions**. Possibility of inhibiting rotation with a lock
- Customisable Labelling System: LCE module made of a transparent protection plug and **customisable tag holder** using the LSE set (available as accessory). The customisation lets you identify the valve on the system according to specific needs
- **DUAL BLOCKB** patented lock system that ensures union nut tightening hold even in severe conditions such as vibrations or heat dilation
- **Double stem** with double O-Rings for ball centring and operating torque reduction
- Machined high surface finish ball that guarantees a smooth operation and increased reliability
  
- Connection system for solvent weld, threaded and flanged joints
- Patented **SEAT STOPB** ball carrier system that lets you micro-adjust seals and minimise axial force effects
- Easy radial dismounting allowing quick replacement of O-rings and ball seats without any need for tools
- **PN16 True Union valve body** made for rigid PVC-U injection moulding equipped with built-in bores for actuation. ISO 9393 compliant test requisites
- Option of dismounting downstream pipes with the valve in the closed position
- **Full bore ball** with high surface finish
- **Integrated bracket** for valve anchoring
- Possibility of installing a manual reducer or pneumatic and/or electric actuators by applying an ISO standard bore PP-GR flange
- **STAINLESS steel co-moulded stem**, with square section as per ISO 5211
- Possibility to have handle with integrated LSQT limit micro switch, even as a retrofit in existing installations