

DKLUIF - DIALOCKB 2-way Βάνα Διαφράγματος

DIALOCK^B diaphragm valve with stroke limiter and female union ends for socket welding, metric series

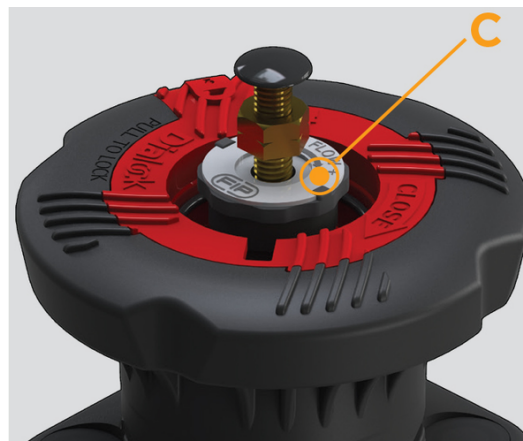
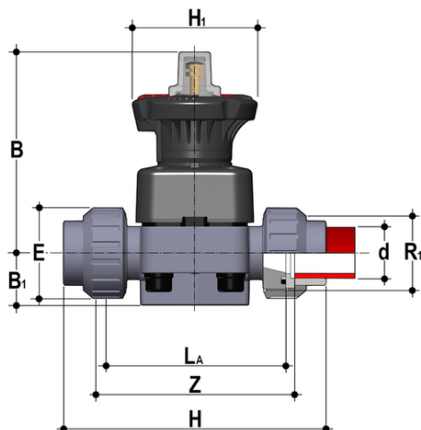

EPDM

Κωδικός Προϊόντος	tooltiplmage	d	DN	PN	B	B[5:1]	E	H	H[5:1]	La	R[5:1]	Z	g
DKLUIF020E	-	20	15	10	115	25	41	129	80	90	1"	100	581
DKLUIF025E	-	25	20	10	118	30	50	154	80	108	1 1/4"	116	666
DKLUIF032E	-	32	25	10	127	33	58	168	80	116	1 1/2"	124	935
DKLUIF040E	-	40	32	10	132	30	72	192	80	134	2"	140	1107
DKLUIF050E	-	50	40	10	175	35	79	222	120	154	2 1/4"	160	2049
DKLUIF063E	-	63	50	10	200	46	98	266	120	184	2 3/4"	190	3295

FKM

Κωδικός Προϊόντος	tooltiplmage	d	DN	PN	B	B[5:1]	E	H	H[5:1]	La	R[5:1]	Z	g
DKLUIF020F	-	20	15	10	115	25	41	129	80	90	1"	100	581
DKLUIF025F	-	25	20	10	118	30	50	154	80	108	1 1/4"	116	666
DKLUIF032F	-	32	25	10	127	33	58	168	80	116	1 1/2"	124	935
DKLUIF040F	-	40	32	10	132	30	72	192	80	134	2"	140	1107
DKLUIF050F	-	50	40	10	175	35	79	222	120	154	2 1/4"	160	2049
DKLUIF063F	-	63	50	10	200	46	98	266	120	184	2 3/4"	190	3295

PTFE

Κωδικός Προϊόντος	tooltiplmage	d	DN	PN	B	B[5:1]	E	H	H[5:1]	La	R[5:1]	Z	g
DKLUIF020P	-	20	15	10	115	25	41	129	80	90	1"	100	581
DKLUIF025P	-	25	20	10	118	30	50	154	80	108	1 1/4"	116	666
DKLUIF032P	-	32	25	10	127	33	58	168	80	116	1 1/2"	124	935

DKLUIF - DIALOCKB 2-way Βάνα Διαφράγματος

Κωδικός Προϊόντος	tooltiplImage	d	DN	PN	B	B[5:1]	E	H	H[5:1]	La	R[5:1]	Z	g
DKLUIF040P	-	40	32	10	132	30	72	192	80	134	2"	140	1107
DKLUIF050P	-	50	40	10	175	35	79	222	120	154	2"1/4	160	2049
DKLUIF063P	-	63	50	10	200	46	98	266	120	184	2"3/4	190	3295

DKLUIF - DIALOCKB 2-way Βάνα Διαφράγματος

- **High visibility graduated optical position indicator** protected by a transparent cap with seal O-Ring
 - **Customisation plate:** the customisation lets you identify the valve on the system according to specific needs
 - **DIALOCKB SYSTEM:** innovative handwheel with a patented immediate and ergonomic operating locking device that allows it **to be adjusted and locked in over 300 positions**
 - **Handwheel and bonnet in** high mechanical strength and chemically resistant **PP-GR**, providing full protection by isolating all internal metal parts from contact with external agents
 - **Floating pin connection** between the control screw and diaphragm to prevent concentrated loads, improve the seal and extend its lifetime
 - **New design of valve body interior: substantially increased flow coefficient** and reduced pressure drop. The degree of efficiency reached has also **enabled the size and weight of the valve to be reduced**
 - **Adjustment linearity:** the internal profiles of the valve also greatly improve its characteristic curve, resulting in **extremely sensitive and precise adjustment** along the entire stroke of the shutter
 - **Valve anchoring** bracket **integrated in the body**, with threaded metal inserts allowing **simple panel or wall mounting** using the PMDK mounting plate (supplied as an accessory)
- Connection system for solvent weld, threaded and flanged joints
 - **Optimised fluid dynamic design:** maximum output flow rate thanks to the optimised efficiency of the fluid dynamics that characterise the new internal geometry of the body
 - **Internal components in metal, totally isolated from the fluid** and external environment
 - **Modularity of the range:** only 2 handwheel and 4 diaphragm and bonnet sizes for 7 different valve sizes
 - Non-rising handwheel that stays at the same height during rotation, equipped with a graduated optical indicator protected by a transparent PVC cap with seal O-Ring
 - Bonnet fastening screws in stainless steel protected against the external environment by PE plugs. Absence of metal parts exposed to the external environment to prevent any risk of corrosion.
 - **CDSA** (Circular Diaphragm Sealing Angle) system that, thanks to the uniform distribution of shutter pressure on the diaphragm seal, offers the following advantages:
 - reduction in the tightening torque of the screws fixing the actuator to the valve body
 - reduced mechanical stress on all valve components (actuator, body and diaphragm)
 - easy to clean valve interior
 - low risk of the accumulation of deposits, contamination or damage to the diaphragm due to crystallisation
 - operating torque reduction