

VRUIM - Αντεπίστροφο Μπίλιας

Check valve with female union ends for socket welding, metric series

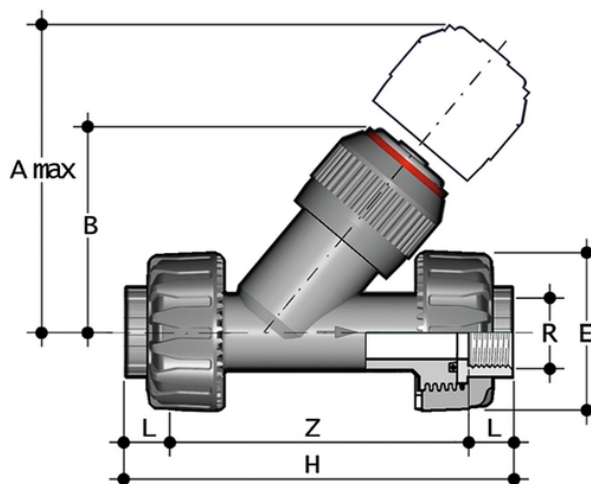

EPDM

Κωδικός προϊόντος	tooltiplmage	d	DN	PN	A max	B	E	H	Z	g
VRUIM020E	-	20	15	10	125	71	55	138	109	165
VRUIM025E	-	25	20	10	145	83	66	157	125	227
VRUIM032E	-	32	25	10	165	94	74	179	143	380
VRUIM040E	-	40	32	10	190	109	86	205	164	645
VRUIM050E	-	50	40	10	210	119	99	244	197	915
VRUIM063E	-	63	50	10	240	143	120	294	239	1555

FKM

Κωδικός Προϊόντος	tooltiplmage	d	DN	PN	A max	B	E	H	Z	g
VRUIM020F	-	20	15	10	125	71	55	138	109	165
VRUIM025F	-	25	20	10	145	83	66	157	125	227
VRUIM032F	-	32	25	10	165	94	74	179	143	380
VRUIM040F	-	40	32	10	190	109	86	205	164	645
VRUIM050F	-	50	40	10	210	119	99	244	197	915
VRUIM063F	-	63	50	10	240	143	120	294	239	1555

VRUIM - Αντεπίστροφο Μπίλιας

- Connection system for weld, threaded and flanged joints
- **No metal parts in contact with the fluid**
- **Piston with counterweight** able to work with high intensity fluid
- Limited pressure drop. Only minimum back pressure is required for the hermetic seal
- **Valve material compatibility** (PP-H) with water conveyance, drinking water and other food substances according to **current regulations**
- Can be maintained with the valve body installed