

VRUIV - Αντεπίστροφο

Check valve with female union ends for solvent welding, metric series

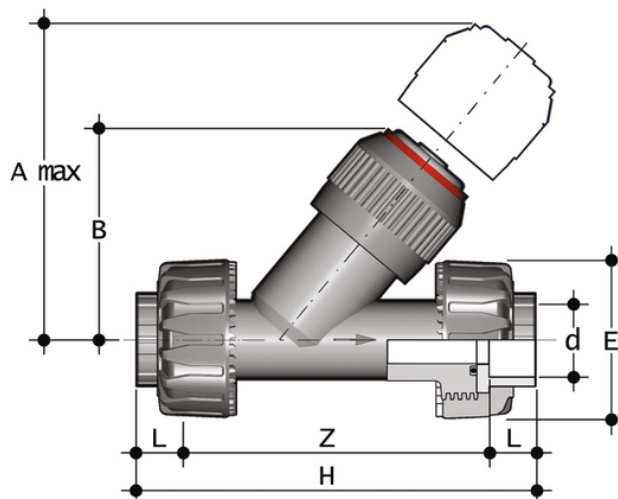

EPDM

Κωδικός προϊόντος	tooltiplmage	d	DN	PN	A max	B	E	H	L	Z	Fig.	g
VRUIV016E	-	16	10	16	125	72	55	135	14	107	A	218
VRUIV020E	-	20	15	16	125	72	55	135	16	103	A	226
VRUIV025E	-	25	20	16	145	84	66	158	19	120	A	388
VRUIV032E	-	32	25	16	165	95	75	176	22	132	A	606
VRUIV040E	-	40	32	16	190	111	87	207	26	155	A	923
VRUIV050E	-	50	40	16	210	120	100	243	31	181	A	1335
VRUIV063E	-	63	50	16	240	139	120	298	38,2	221,6	A	2313

FKM

Κωδικός προϊόντος	tooltiplmage	d	DN	PN	A max	B	E	H	L	Z	Fig.	g
VRUIV016F	-	16	10	16	125	72	55	135	14	107	A	218
VRUIV020F	-	20	15	16	125	72	55	135	16	103	A	226
VRUIV025F	-	25	20	16	145	84	66	158	19	120	A	388
VRUIV032F	-	32	25	16	165	95	75	176	22	132	A	606
VRUIV040F	-	40	32	16	190	111	87	207	26	155	A	923
VRUIV050F	-	50	40	16	210	120	100	243	31	181	A	1335
VRUIV063F	-	63	50	16	240	139	120	298	38,2	221,6	A	2313

VRUIV - Αντεπίστροφο

- Connection system for solvent weld, threaded and flanged joints
- **No metal parts in contact with the fluid**
- **Piston with counterweight** able to work with high intensity fluid
- Limited pressure drop. Only minimum back pressure is required for the hermetic seal
- **Valve material compatibility** (PVC-U) with water conveyance, drinking water and other food substances according to **current regulations**
- Can be maintained with the valve body installed