

RVIV-RVIT - Φίλτρο

RVIV PVC-U rigid - RVIT PVC-U transparent Sediment strainer with female ends for solvent welding

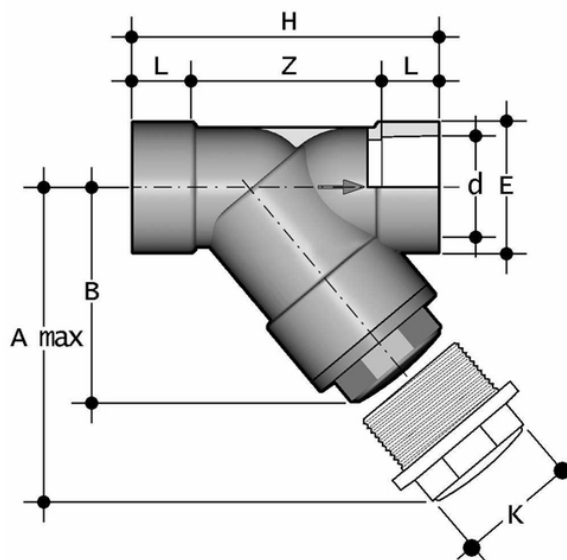

EPDM

| Κωδικός προϊόντος | tooltiplmage | d | DN | PN RVIV | PN RVIT | A max | B | E | H | K | L | Z | Fig. | g |
|-------------------|--------------|-----|-----|---------|---------|-------|-----|-----|-----|-----|----|-----|------|------|
| RVIV075E | - | 75 | 65 | 10 | 6 | 300 | 179 | 104 | 243 | 96 | 33 | 155 | B | 2385 |
| RVIV090E | - | 90 | 80 | 6 | 4 | 325 | 192 | 116 | 262 | 105 | 37 | 160 | B | 2975 |
| RVIV110E | - | 110 | 100 | 6 | 4 | 385 | 231 | 138 | 325 | - | 61 | 203 | C | 4610 |
| RVIT075E | - | 75 | 65 | 10 | 6 | 300 | 179 | 104 | 243 | 96 | 33 | 155 | B | 2385 |
| RVIT090E | - | 90 | 80 | 6 | 4 | 325 | 192 | 116 | 262 | 105 | 37 | 160 | B | 2975 |
| RVIT110E | - | 110 | 100 | 6 | 4 | 385 | 231 | 138 | 325 | - | 61 | 203 | C | 4610 |



RVIV-RVIT - Φίλτρο

- Connection system for solvent weld, threaded and flanged joints
- **Strainer** mounted on an easily removed **support** that facilitates the cleaning or replacement
- **Valve material compatibility** (PVC-U) with water conveyance, drinking water and other food substances according to **current regulations**
- Can be maintained with the valve body installed