

# VKDIV/CE 90-240 V AC - DUAL BLOCKB 2-WAY Βάνα Σφαιρική με Ηλεκτρικό Ενεργοποιητή

DUAL BLOCKB ball valve with female ends for solvent welding, metric series with multi-volt electric actuator 90-240 V AC 50-60 Hz

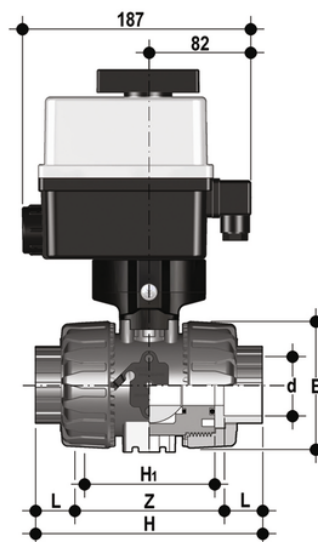

## EPDM

Κωδικός προϊόντος	tooltiplmage	d	DN	PN	E	H	H1	L	Z	B	B <sub>1</sub>	g
VKDIVEM016E	-	16	10	16	54	103	65	14	75	205	29	1785
VKDIVEM020E	-	20	15	16	54	103	65	16	71	205	29	1775
VKDIVEM025E	-	25	20	16	65	115	70	19	77	216	34.5	1903
VKDIVEM032E	-	32	25	16	73	128	78	22	84	221	39	2011
VKDIVEM040E	-	40	32	16	86	146	88	26	94	238	46	2369
VKDIVEM050E	-	50	40	16	98	164	93	31	102	244	52	2601
VKDIVEM063E	-	63	50	*10	122	199	111	38	123	261	62	3218

## FKM

Κωδικός Προϊόντος	tooltiplmage	d	DN	PN	E	H	H1	L	Z	B	B <sub>1</sub>	g
VKDIVEM016F	-	16	10	16	54	103	65	14	75	205	29	1785
VKDIVEM020F	-	20	15	16	54	103	65	16	71	205	29	1775
VKDIVEM025F	-	25	20	16	65	115	70	19	77	216	34.5	1903
VKDIVEM032F	-	32	25	16	73	128	78	22	84	221	39	2011
VKDIVEM040F	-	40	32	16	86	146	88	26	94	238	46	2369
VKDIVEM050F	-	50	40	16	98	164	93	31	102	244	52	2601
VKDIVEM063F	-	63	50	*10	122	199	111	38	123	261	62	3218

# VKDIV/CE 90-240 V AC - DUAL BLOCKB 2-WAY Βάννα Σφαιρική με Ηλεκτρικό Ενεργοποιητή

In addition to the manually actuated version, VKD is also available in VKD/CE electrically actuated and VKD/CP pneumatically actuated configurations. Actuators are firmly connected to the valve by the special FIP Power Quick modules fully made of PP-GR technopolymer. VKD/CE and VKD/CP are constructed with actuators meeting current regulations and selected by FIP according to their quality and reliability requirements. The efficiency of these valves, tested according to the company's quality standards, is guaranteed by the expertise and know-how that FIP dedicates to manufacturing its products.

- Electric actuator constructed according to FIP specifications; with plastic shell and standard emergency override. Available with voltages from 12 to 240V.
- Rack & pinion type pneumatic actuator constructed according to FIP specifications: fully protected against weather corrosion available in double-acting (DA) or simple-acting normally closed (NC) or normally open (NO) versions.
- DUAL BLOCKB patented lock system that ensures union nut tightening hold even in severe conditions such as vibrations or heat dilation.
- Double stem with double O-Rings for ball centring and operating torque reduction. The upper stem is also equipped with a co-moulded steel insert that guarantees high durability and perfect torque transmission between the actuator and ball.
- Joint system for solvent welding (PVC-U and PVC-C only), for welding (PP-H and PVDF only), for threading and flanging
- Patented SEAT STOPB ball carrier system that lets you micro-adjust ball seats and minimise the axial force effect.
- Easy radial disassembly allowing quick replacement of O-rings and ball seats without any need for tools
- Radial dismounting valve body (True Union) made for PVC-U, PVC-C and PP-H injection moulding equipped with built-in bores for actuation. ISO 9393 compliant test requisites
- Option of disassembling downstream pipes with the valve in the closed position
- Floating full bore ball with high surface finish
- Integrated bracket for valve anchoring
- Possibility of installing a gear box or pneumatic and/or electric actuators by applying an ISO standard bore PP-GR flange
- Stainless steel co-moulded stem, with square section as per ISO 5211.