

# GBM

90B° bend, short spigot for butt welding SDR 17,6 - 8,3

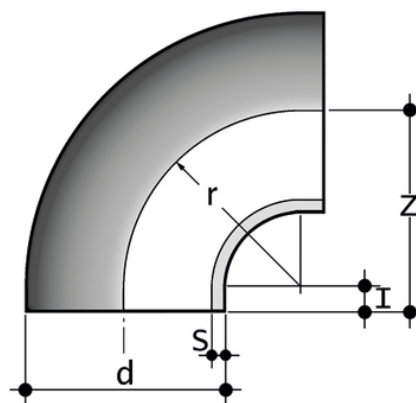

Κωδικός Προϊόντος	tooltiplmage	d	l	r	s	Z	g
GBM17125	-	125	15	125	7,1	140	652
GBM17140	-	140	15	140	8	155	900
GBM17160	-	160	15	160	9,1	175	1231
GBM17180	-	180	15	180	10,2	195	1875
GBM17200	-	200	15	200	11,4	215	2423
GBM17225	-	225	20	225	12,8	245	3469
GBM17250	-	250	25	250	14,2	275	4568
GBM17280	-	280	30	280	15,9	310	6550
GBM17315	-	315	35	315	17,9	350	9728
GBM17355	-	355	38	355	20,1	385	19365
GBM17400	-	400	41	400	22,7	438	28650
GBM17450	-	450	60	450	25,5	510	52551
GBM17500	-	500	60	500	28,3	560	28650
GKM17050	-	50	7	55	2,9	62	47
GKM17063	-	63	8	69	3,6	77	89
GKM17075	-	75	10	75	4,3	85	152
GKM17090	-	90	10	90	5,1	100	245
GKM17110	-	110	10	110	6,3	120	422