

# GBM

90B° bend, short spigot for butt welding SDR 11 - S 5

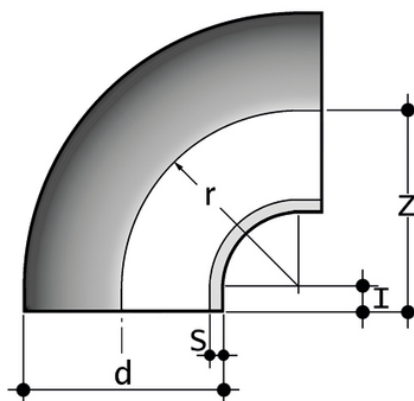

Κωδικός Προϊόντος	tooltiplmage	d	l	r	s	Z	g
GBM11125	-	125	15	125	11,4	140	945
GBM11140	-	140	15	140	12,7	155	1300
GBM11160	-	160	15	160	14,6	175	1870
GBM11180	-	180	15	180	16,4	195	2767
GBM11200	-	200	15	200	18,2	215	3604
GBM11225	-	225	20	225	20,5	245	5292
GBM11250	-	250	25	250	22,7	275	7210
GBM11280	-	280	30	280	25,4	310	10020
GBM11315	-	315	35	315	28,6	350	13965
GBM11355	-	355	38	355	32,2	385	12760
GBM11400	-	400	41	400	36,3	438	18500
GBM11450	-	450	60	450	40,9	510	18500
GBM11500	-	500	60	500	45,4	560	18500
GKM11020	-	20	3	24	1,9	27	5
GKM11025	-	25	5	27	2,3	32	9
GKM11032	-	32	5	35	2,9	40	17
GKM11040	-	40	7	44	3,7	51	36
GKM11050	-	50	7	55	4,6	62	66
GKM11063	-	63	8	69	5,8	77	124
GKM11075	-	75	10	75	6,8	85	210



**GBM**

Κωδικός Προϊόντος	tooltiplmage	d	l	r	s	Z	g
GKM11090	-	90	10	90	8,2	100	355
GKM11110	-	110	10	110	10	120	616

