

DAA

Pressure Tapping Tees with extra long outlet spigot

Leak free and swarfless tapping up to 10 bar (gas) or 16 bar (water). Integrated drill with solid upper and lower stop, incl. integrated torque limiter.

A complete tool-free mounting of the saddle by innovative fast clamping system (RED SNAP). By new design, 54 % of total installation time can be saved.

With exposed heating element for optional heat transfer. End plug with internal O-Ring seal. Optional protection against any access with fusion of the FRIALEN cap K d 50 (order no. 612310)

Only one actuation key FWSS SW 17 (see application picture; order no. 613246) for all dimensions and if necessary as extension ratchet FWST T (order no. 613615; see product range FRIATOOLS).

Length of the outlet spigots dimensioned for 2 fusion operations.

When using hydrogen, the DAA pressure tapping fitting should only be used in conjunction with sealing cap K (order no. 612310).

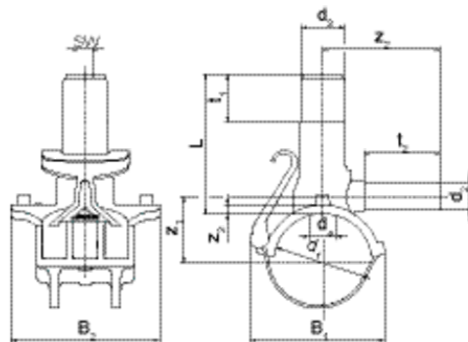

PE 100 SDR 11

Maximum working pressure 16 bar (water)/10 bar (gas)



Κωδικός Προϊόντος	product.detail.attribute.d1Small	d ₂	BX	PU	d ₃	L	t ₁	t ₂	z ₁	z ₂	z ₃	B1	B2	SW	Drilling Ø d _a	Weight kg
612630	40	20	30	240	50	120	50	66	32	105	8	85	136	17	25	0,370
616473	40	25	30	240	50	120	50	83	32	122	8	85	136	17	25	0,380
616474	40	32	30	240	50	120	50	86	32	125	8	85	136	17	25	0,385
616475	50	20	28	224	50	120	50	66	37	108	8	95	136	17	25	0,385
612702	50	25	28	224	50	120	50	83	37	125	8	95	136	17	25	0,390
615080	50	32	28	224	50	120	50	86	37	128	8	95	136	17	25	0,400
612631	63	20	20	160	50	130	50	66	51	100	10	108	146	17	25	0,450
612633	63	25	20	160	50	130	50	83	51	118	10	108	146	17	25	0,460
612632	63	32	20	160	50	130	50	86	51	123	10	108	146	17	25	0,465

Pressure Tapping Tees with extra long outlet spigot

Κωδικός Προϊόντος	product.detail.attribute.d1Small	d ₂	BX	PU	d ₃	L	t ₁	t ₂	z ₁	z ₂	z ₃	B1	B2	SW	Drilling Ø d _a	Weight kg
616472	63	40	16	128	50	160	50	115	51	165	10	108	146	17	30	0,855
616334	63	63	16	128	50	160	50	115	51	165	10	108	146	17	30	0,635
616482	75	32	24	192	50	130	50	86	57	126	10	120	146	17	25	0,485
616483	90	20	14	112	50	160	50	66	66	106	10	137	170	17	30	0,600
616484	90	25	14	112	50	160	50	83	66	123	10	137	170	17	30	0,610
612634	90	32	14	112	50	160	50	86	66	126	10	137	170	17	30	0,615
615656	90	40	14	112	50	160	50	115	66	168	10	137	170	17	30	0,950
616476	90	50	14	112	50	160	50	115	66	168	10	137	170	17	30	0,960
612701	90	63	14	112	50	160	50	115	66	168	10	137	170	17	30	0,730
616487	110	20	14	112	50	160	50	66	76	111	10	152	170	17	30	0,620
616488	110	25	14	112	50	160	50	83	76	128	10	152	170	17	30	0,625
612637	110	32	14	112	50	160	50	86	76	134	10	152	170	17	30	0,630
615662	110	40	14	112	50	160	50	115	76	175	10	152	170	17	30	1,000
616477	110	50	14	112	50	160	50	115	76	175	10	152	170	17	30	1,010
612624	110	63	14	112	50	160	50	115	76	175	10	152	170	17	30	0,780
616491	125	20	12	96	50	160	50	66	83	111	10	167	170	17	30	0,650
616492	125	25	12	96	50	160	50	83	83	131	10	167	170	17	30	0,655
612649	125	32	12	96	50	160	50	86	83	138	10	167	170	17	30	0,670
615668	125	40	12	96	50	160	50	115	83	180	10	167	170	17	30	1,020
616478	125	50	12	96	50	160	50	115	83	180	10	167	170	17	30	1,030
612309	125	63	12	96	50	160	50	115	83	180	10	167	170	17	30	0,800
616495	140	32	12	96	50	160	50	86	91	141	10	170	170	17	30	0,700
616496	140	63	12	96	50	160	50	115	91	185	10	170	170	17	30	0,830
616497	160	20	10	80	50	160	50	66	106	108	10	195	186	17	30	0,730
616498	160	25	10	80	50	160	50	83	106	128	10	195	186	17	30	0,735
612641	160	32	10	80	50	160	50	86	106	137	10	195	186	17	30	0,745
615675	160	40	10	80	50	160	50	115	106	185	10	195	186	17	30	1,095
616480	160	50	10	80	50	160	50	115	106	185	10	195	186	17	30	1,105
612650	160	63	10	80	50	160	50	115	106	185	10	195	186	17	30	0,875
616501	180	20	10	80	50	190	50	66	116	110	10	203	186	17	30	0,785
616502	180	25	10	80	50	190	50	83	116	132	10	203	186	17	30	0,790
612651	180	32	10	80	50	190	50	86	116	141	10	203	186	17	30	0,790
616481	180	50	10	80	50	190	50	115	116	188	10	203	186	17	30	1,170
612652	180	63	10	80	50	190	50	115	116	188	10	203	186	17	30	0,940
612654	200	32	8	64	50	190	50	86	126	144	10	205	186	17	30	0,810

DAA

Pressure Tapping Tees with extra long outlet spigot

Κωδικός Προϊόντος	product.detail.attribute.d1Small	d ₂	BX	PU	d ₃	L	t ₁	t ₂	z ₁	z ₂	z ₃	B1	B2	SW	Drilling Ø d _a	Weight kg
612659	200	63	8	64	50	190	50	115	126	190	10	205	186	17	30	0,950
612657	225	32	8	64	50	190	50	86	138	146	10	214	186	17	30	0,835
616486	225	50	8	64	50	190	50	115	138	197	10	214	186	17	30	1,210
612655	225	63	8	64	50	190	50	115	138	197	10	214	186	17	30	0,980

FRIALEN Pressure Tapping Tees d 40 can be fused to pipes SDR 11 and \geq d 50 to pipes SDR 11 - 17.6. Other SDR on request. Please observe the marking directly at the product, which is mandatory.

DVGW-Registration No. DV-6611CS0007

DAA

Pressure Tapping Tees with extra long outlet spigot

Areas of Application

The FRIALEN Pressure Tapping Tees DAA are used as branch fittings and can be fused to mains that are unpressurised or under operating pressure.

Assembly Instructions

The fusion of FRIALEN Pressure Tapping Tee DAA to the PE-HD main and the service pipe takes place by FRIALEN fusing – leakproof and longitudinally strong.

The pipe, saddle and the outlet spigot are prepared (oxide layer removed/cleaned) in accordance with the general installation instructions (see "Assembly instructions" for FRIALEN Safety Fittings for house connections and distribution pipes up to d 225).

Thanks to its innovative and patented clamping mechanism, the FRIALEN Pressure Tapping Tee DAA can also be installed without any tool quickly and reliably on the HD-PE main when it exhibits ovality or has expanded under operating pressure.

Good reasons for using the FRIALEN Pressure Tapping Tees DAA:

Compact design

Simple and reliable assembly without any tool thanks to the patented fast clamping lever

The flexible saddle compensates pipe tolerances and always provides optimal, uniform buildup of melt pressure during fusion

Assembly without special tools

The Pressure Tapping Tee is one unit with captive parts

Only one 17 mm wrench size for tapping and installing the plug

Chipless tapping

Leak-free tapping under operating pressure

Low torque needed for tapping

Punched-out pipe piece fits securely in the drill

Stable thread as guidance for the driller during tapping process even at large pipe wall thicknesses and low temperatures

Solid upper and lower stop of driller, with integrated torque limiter

Extra wide fusion zone

After tapping, stack can be fused non-accessible with FRIALEN cap K

Outlet spigot length measured for two fusion operations

Additional barcode for traceability (traceability coding)

Both barcodes exposed on fast clamping lever for easy scanning with readerwand or barcode scanner