

KHW

Σφαιρικές βάνες από HD-PE κατάλληλο για πόσιμο νερό, 1/4-Στροφή, με πλήρη πέρασμα

Compact ball valve made from HD-PE with spigots for processing with FRIALEN MB or UB couplers. Full port valve passage in line with internal diameter of pipe socket. No corrosion prevention measures necessary. Open and closed position at defined stop. Maintenance free shut-off valve activated by a rod (e.g. FRIALEN BS).

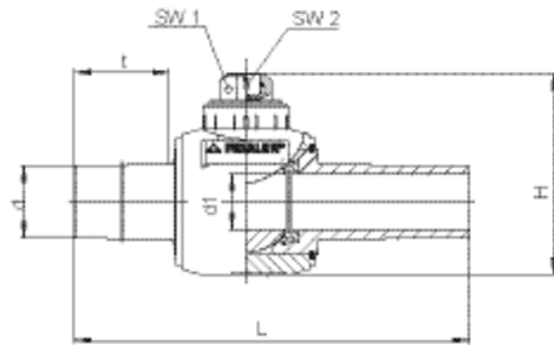
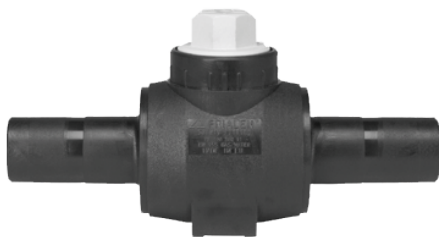

PE 100 SDR 11

Maximum working pressure 16 bar (water)



	Κωδικός προϊόντος	d	product.detail.attribute.dSmall	BX	PU	L	t	sw1	sw2	H	Weight kg
	616656	32	34	1	100	324	108	50 x 50	20	156	0,770
	616657	40	34	1	100	324	108	50 x 50	20	156	0,800
1	616658	50	43	1	50	405	129	50 x 50	25	193	2,240
	616659	63	51	1	50	410	134	50 x 50	25	206	2,420

¹ Please choose the suitable installation kit d 63 - d 225

FRIALEN-Safety Fittings can be fused to pipes of SDR-stages 11 to 17.6. Minimum wall thickness $s_{min} \geq 3$ mm. Other SDR-stages on request. Please observe the marking directly at the product, which is mandatory.

DVGW-Registration No.: DW-6210CQ0059

KHW

Σφαιρικές βάνες από **HD-PE** κατάλληλο για πόσιμο νερό, **1/4-Στροφή**, με **πλήρη πέρασμα**

Areas of Application

The FRIALEN-Ball Valve KHW with NBR-sealing with drinking water approval is suitable for shutting off sections of the main and also for isolating house connection pipes. The Ball Valve KHW can be applied in pipe systems for water supply, for compressed sewage, mineral and sea water pipes.

Further media on request.

The passage of the valve (d1) corresponds approx. with the internal diameter of the pipe socket SDR without constriction.

The Ball Valve KHW is opened and closed by a 1/4-turn with the installation kit BS. The installation kit BS allows the operation from the street cap and is optimal adapted to the FRIALEN-Ball Valve KHW. For further information see this data sheet page 2. or data sheet installation kit BS No. 22/00.

Assembly Instructions

The FRIALEN-Ball Valve KHW is connected to the pipe by using Couplers, Elbows or T-Pieces fused to its ends.

The connection with HD-PE pipes takes place by FRIALEN-fusing – leakproof and longitudinally strong.

The spigot ends to be fused are prepared according to the general installation instructions (see "Assembly Instructions" for "FRIALEN-Safety Fittings for house connections and distribution pipes up to d 225"). This involves removing the oxide layer and cleaning the pipe ends.

Before fusion the FRIALEN-Ball Valve KHW must be lined up to suit the type of actuation intended, in order to ensure that the installation kit BS will be placed correctly.

Good reasons for using the FRIALEN-Ball Valve KHW:

The FRIALEN-Ball Valve provides a completely fused HD-PE pipe network, without transitions to other materials or flange connections

Another step towards a pure PE-pipe system

Optimum hydraulics due to pipe identical passage and contour providing ease of flow

Good testability due to lack of constriction of internal diameter

Floating ball, axial seals in the ball axle and combination of ball guidance and ball seal in one part compensate for bending defects

No deposits on internal areas, resistant to chemical and electrical reactions

No corrosion proofing required

Optimum hydraulics due to pipe identical passage and contour providing ease of flow, optimum flow speed

Low activating element, low weight

Extra long spigot ends dimensioned for two fusion operations

Actuating of the KHW with the telescopic installation kit BS

Additional barcode for tracing back the underground fitting (Traceability-Coding)