

# SA VL

## Spigot Σέλα SA XL

For integration of a branch line or vent in PE pipelines with large diameters –unpressurised or under operating pressure. Compact fitting made of HD-PE. Saddle with exposed heating element for optimal heat transfer. Outlet spigot for processing with FRIALEN couplers MB or UB.

The SA XL spigot saddle is assembled using a FRIATOOLS vacuum pump (see left application picture; order no. 613827) and the corresponding FRIATOOLS plunger (see Product Range FRIATOOLS).

Tapping in unpressurised condition with FRIATOOLS tapping kit FWAB XL (see right application picture and Product Range FRIATOOLS) or, using an additional shut-off valve, under operating pressure using commercially available drilling equipment (we recommend Hütz & Baumgarten: [www.huetz-baumgarten.de](http://www.huetz-baumgarten.de)).

For tapping under pressure, please contact our hotline: +49 621 486-2325.

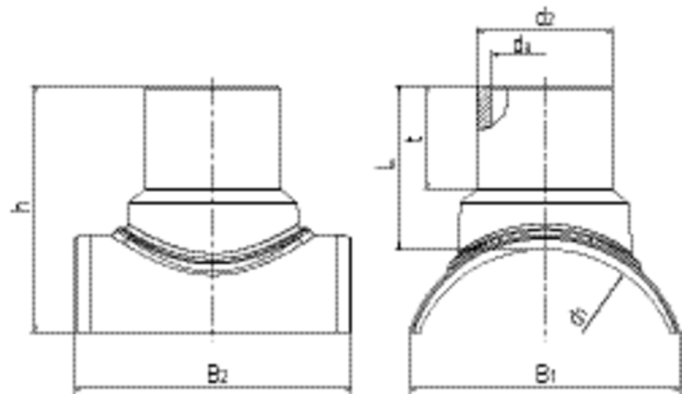

Κωδικός Προϊόντος	product.detail.attribute.d1Small	d <sub>2</sub>	BX	PU	L	t	h	B1	B2	Drilling Ø d <sub>a</sub>	Weight kg
616469	400	225	1	4	263	210	403	483	530	172	14,700
616779	400	250	1	4	261	210	417	483	530	187	15,200
616780	450	225	1	4	267	210	421	530	530	172	17,500
616781	450	250	1	4	272	210	426	530	530	187	18,000
616391	500	225	1	4	265	210	388	521	530	172	14,500
616782	500	250	1	4	263	210	380	521	530	187	15,500
616783	500	280	1	4	265	210	388	521	590	225	15,600
616784	500	315	1	4	268	210	446	573	590	254	21,600
616392	560	225	1	4	263	210	402	577	530	172	15,700
616785	560	250	1	4	263	210	398	577	530	187	17,000
616786	560	280	1	4	265	210	404	577	590	225	17,000

# SA VL

## Spigot Σέλα SA XL

Κωδικός Προϊόντος	product.detail.attribute.d1Small	d <sub>2</sub>	BX	PU	L	t	h	B1	B2	Drilling Ø d <sub>a</sub>	Weight kg
616787	560	315	1	4	268	210	402	564	590	254	19,800
616788	560	355	1	4	260	210	451	618	630	286	26,000
616789	560	400	1	4	260	210	451	618	630	322	27,200
616393	630	225	1	4	265	210	422	634	530	172	17,000
616790	630	250	1	4	267	210	419	634	530	187	17,500
616791	630	280	1	4	263	210	420	634	590	225	18,000
616792	630	315	1	4	265	210	417	621	590	254	20,900
616793	630	355	1	4	269	220	422	616	630	286	23,800
616794	630	400	1	4	267	220	419	616	630	322	25,000
616394	710	225	1	4	270	210	447	712	530	172	20,500
616795	710	250	1	4	265	210	437	712	530	187	22,100
616796	710	280	1	4	268	210	445	712	590	225	21,500
616797	710	315	1	4	268	210	439	694	590	254	23,800
616798	710	355	1	4	285	220	457	694	630	286	28,500
616762	710	400	1	4	275	220	447	694	630	322	29,500
616395	800	225	1	4	270	210	381	643	530	172	17,300
616799	800	250	1	4	275	210	384	643	530	187	18,600
616800	800	280	1	4	268	210	382	643	590	225	18,600
616801	800	315	1	4	268	210	377	629	590	254	20,500
616802	800	355	1	4	290	220	483	772	630	286	31,200
616803	800	400	1	4	275	220	468	772	630	322	31,600
616396	900	225	1	4	268	210	396	714	530	172	19,000
616804	900	250	1	4	278	210	402	714	530	187	20,700
616805	900	280	1	4	268	210	396	714	590	225	20,300
616806	900	315	1	4	269	210	393	700	590	254	23,000
616807	900	355	1	4	305	220	429	700	630	286	27,300
616808	900	400	1	4	275	220	399	700	630	322	28,000
616397	1000	225	1	4	270	210	396	653	530	172	18,000
616809	1000	250	1	4	280	210	366	653	530	187	19,300
616810	1000	280	1	4	270	210	361	653	590	225	19,000
616811	1000	315	1	4	270	210	358	642	590	254	21,000
616812	1000	355	1	4	305	220	444	774	630	286	30,800
616813	1000	400	1	4	278	220	417	774	630	322	31,300
616384	1200	225	1	4	270	210	346	655	530	172	17,500
616814	1200	250	1	4	284	210	354	655	530	187	19,200

# SA VL

## Spigot Σέλα SA XL

Κωδικός Προϊόντος	product.detail.attribute.d1Small	d <sub>2</sub>	BX	PU	L	t	h	B1	B2	Drilling Ø d <sub>a</sub>	Weight kg
616815	1200	280	1	4	270	210	345	655	590	225	18,600
616816	1200	315	1	4	270	210	343	645	590	254	20,800
616817	1200	355	1	4	305	220	413	759	630	286	29,600
616818	1200	400	1	4	278	220	385	759	630	322	30,300

Κωδικός Προϊόντος	product.detail.attribute.d1Small	d <sub>2</sub>	BX	PU	L	t	h	B1	B2	Drilling Ø d <sub>a</sub>	Weight kg
616378	1000	160	1	4	300	249	390	654	530	123	17,350
616383	1200	160	1	4	300	250	375	655	530	123	17,200

# SA VL

## Spigot Σέλα SA XL

### Areas of Application

Create highly economical branches!

Instead of cost-intensively integrating a T-piece, a branch or vent can be very comfortably created using the new FRIALEN XL spigot saddle SA XL.

### Assembly Instructions

A simple assembly, comfortable handling and short processing time characterise the optimised and construction site-appropriate clamping method for large saddle component parts.

Branch saddle as branch: Your benefit – simple assembly!

The spigot saddles SA XL permit creating also large-volume branches at main pipes – unpressurised or under operating pressure – with less effort, minimal underground work and above all without interrupting the supply.

The saddle can be fixed at any position on the pipe. Thanks to the clamping method specifically developed for SA XL, only access to the covered saddle area is required. Specifically in the case of connections to existing pipelines, the bedding in the pipeline zone is only disturbed as absolutely necessary.

Vacuum clamping technology: Your benefit – comfortable handling!

The clamping force of the saddle required for fusion and built-up of the joining pressure is applied by a vacuum. This only requires a compressor usual for construction sites and the VACUSET. Out-of-roundnesses and shape deviations of the pipe usually seen at construction sites can be bridged by the clamping method.

But it is above all the required space in the pipe trench – and thus cost-intensive underground work – which is minimised for access to the pipe.

The tapping diameter is almost identical with the pipe's diameter of the outlet spigot such that pressure losses are minimised.

Thanks to the use of preheating technology, the two joining partners (pipe surface and saddle area) are uniformly adjusted.

Your benefit: Little time required!

Commissioning is possible with only a few actions. Short assembly and fusion times, short cooling times and a quick tapping permit a branch to be completed in almost no time at all!

### Good reasons for using FRIALEN XL Spigot Saddle

#### SA XL:

Compact construction

HD-PE saddle with exposed heating element for optimal heat transfer

Low tapping forces

Burr-free and almost flush tapping for maximum hydraulic performance

Leakage free tapping possible by means of a shut-off element

Extra wide fusion zone

## SA VL

### Spigot Σέλα SA XL

Additional barcode for tracing back the underground fitting (Traceability-Coding)

Touch proof electric contacts

Easy and safe assembly by vacuum clamping technology

Preheating technology for optimum alignment of the joining partners

Fusion indicators for visual fusion control

Durable batch marking

Individually wrapped for dirt protection