

RSV

Σέλα επισκευής και ενίσχυσης

Compact fitting consisting of one repair saddle and one reinforcing saddle for the repair of minor pipe damage. With exposed heating elements for optimal heat transfer.

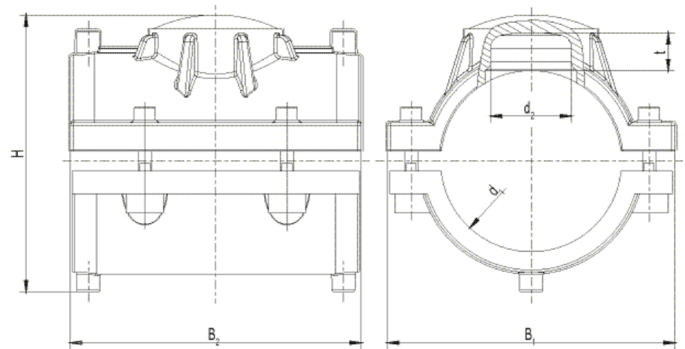

RSV

Σέλα επισκευής και ενίσχυσης

Areas of Application

The FRIALEN-Repair and Reinforcing Saddles are used for the repair of minor pipe damages.

Assembly Instructions

The fusion of the HD-PE pipe with the FRIALEN-Repair and Reinforcing Saddle takes place by FRIALEN-fusing – leakproof and longitudinally strong.

In order to avoid discharge of media, the leak has to be sealed with a separate plug ($\leq d_2$).

Both HD-PE saddles have to be prepared according to the general installation instructions (see "Assembly Instructions" for "FRIALEN-Safety Fittings for house connections and distribution pipes up to d 225"). This includes removing the oxide layer and cleaning the pipe covered by the saddles.

Good reasons for using the FRIALEN-VVS:

Compact construction

HD-PE saddle with exposed heating element for optimal heat transfer

Sealing area free of heating wires

Preassembled unit without loose parts

Extra wide fusion zone

Additional barcode for tracing back the fitting (Traceability-Coding)