

# DAV ACW

## Tapping valve DAV RED SNAP, SDR 11 (closing in an anti-clockwise direction)

Tapping valve DAV RED SNAP ACW, SDR 11

- Gas, water and H<sub>2</sub>
- Maximum pressure: Gas 10 bar, Water 16 bar
- Material: PE 100
- Quick release mechanism (RED SNAP):
  - Simple and error-free assembly
  - More quality and high security
  - Save 50% of installation time
- Integrated drill with upper and lower inner stop
- Maximum 9 turns for opening and closing
- Safety technology
- DVGW test mark: DV-6611AU2255

### Note:

For this purpose, there is a suitable actuating linkage DBS with KlickFix and foam rubber for wrench size SW14.

The output nominal size 63 / 40 is a solution with reducing socket MR.

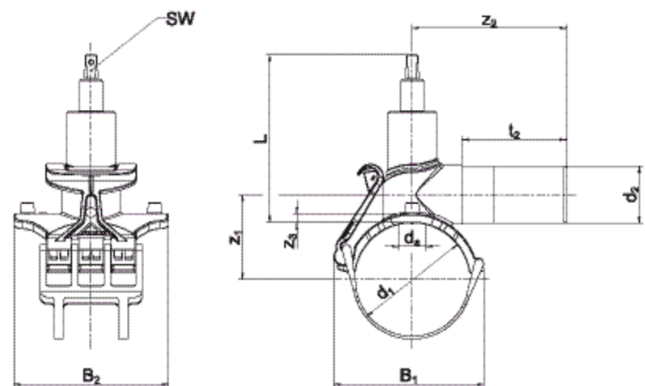

PE 100 SDR 11

Maximum permissible working pressure 16 bar (water) / 10 bar (gas)



Reference	d <sub>1</sub>	d <sub>2</sub>	BX	PU	L	t <sub>2</sub>	z <sub>1</sub>	z <sub>2</sub>	z <sub>3</sub>	B <sub>1</sub>	B <sub>2</sub>	SW	Drilling Ø d <sub>a</sub>	Turns open/close	Weight kg
617127	50	32	24	192	177	86	56	125	8	95	136	14	30	7	1,210
617128	63	32	24	192	177	86	63	125	10	108	146	14	30	7	1,210
617129	63	63	20	160	177	115	63	155	10	108	146	14	30	7	1,330
617130	75	32	20	160	177	86	69	125	10	120	146	14	30	7	1,040

# DAV ACW

## Tapping valve DAV RED SNAP, SDR 11 (closing in an anti-clockwise direction)

Reference	d <sub>1</sub>	d <sub>2</sub>	BX	PU	L	t <sub>2</sub>	z <sub>1</sub>	z <sub>2</sub>	z <sub>3</sub>	B1	B2	SW	Drilling Ø d <sub>a</sub>	Turns open/close	Weight kg
617131	90	32	12	96	183	86	76	125	10	137	170	14	30	8	1,210
617132	90	63	12	96	183	115	76	165	10	137	170	14	30	8	1,330
617133	110	32	12	96	183	86	86	125	10	152	170	14	30	8	1,230
617134	110	63	12	96	183	115	86	170	10	152	170	14	30	8	1,360
617135	125	32	12	96	183	86	94	125	10	167	170	14	30	8	1,260
617136	125	63	12	96	183	115	94	170	10	167	170	14	30	8	1,380
617137	140	32	12	96	183	86	101	125	10	170	170	14	30	8	1,230
617138	140	63	12	96	183	115	101	175	10	170	170	14	30	8	1,360
617139	160	32	10	80	208	86	111	130	10	195	186	14	30	9	1,410
617140	160	63	10	80	208	115	111	180	10	195	186	14	30	9	1,550
617141	180	32	10	80	208	86	121	130	10	203	186	14	30	9	1,440
617142	180	63	10	80	208	115	121	180	10	203	186	14	30	9	1,570
617143	200	32	8	64	208	86	131	130	10	205	186	14	30	9	1,440
617144	200	63	8	64	208	115	131	185	10	205	186	14	30	9	1,590
617145	225	32	8	64	208	86	144	135	10	214	186	14	30	9	1,470
617146	225	63	8	64	208	115	144	190	10	214	186	14	30	9	1,620

FRIALEN pressure tapping valves ≤ d 63 are applicable for pipes of SDR level 11 and > d 63 for pipes of SDR level 11 to 17.6. Minimum wall thickness s minimum ≥ 3 mm. Other levels of SDR can be processed on request. Please note the mandatory labels directly on the product. DVGW test mark issued: DV-6611AU2255.

## Tapping valve DAV RED SNAP, SDR 11 (closing in an anti-clockwise direction)

### Areas of Application DAV ACW RED SNAP

The FRIALEN-Pressure Tapping Valves DAV ACW RED SNAP (closing in an anti-clockwise direction) are used for branches of unpressurised and pressurised gas and water pipelines. Outlet spigots are prepared for integration of excess flow valves.

### Assembly Instructions

The fusion of the HD-PE distribution pipes and the service pipes with FRIALEN-Pressure Tapping Valves takes place by FRIALEN-fusing – leakproof and longitudinally strong.

The saddle and the outlet spigot have to be prepared according to the general assembly instructions (see “Assembly Instructions” for “FRIALEN-Safety Fittings for house service and supply pipes up to d 225”). This involves removing the oxide layer and cleaning the pipe surface covered by the saddle as well as the outlet spigot and the pipe end.

The assembly of the pressure tapping valve with fast clamping mechanism takes place within seconds with the fast clamping lever RED SNAP without additional tools.

For „Open/Close“ the pressure tapping valve require 8 to 9 turns, depending to the dimension and design, by using an operating key type E according to DIN 3223.

(The tapping process need less turns, because of the intermediate position of the drill in supplied condition).

### Good reasons for using the FRIALEN Pressure Tapping Valves DAV ACW with fast clamping lever RED SNAP:

- Compact part, solid injection molded body made from HD-PE
- Simple and reliable assembly without any tool, thanks to the patented fast clamping lever RED SNAP
- The flexible saddle compensates pipe tolerances and provides always an optimal, uniform buildup of melt pressure during the fusion
- Fusing and tapping of the main under maximum permitted operating pressure gas/water
- Simple start-up of the pressure tapping valve because of little tapping forces
- No preventive measures necessary with regard to corrosion
- Actuating spindle made from corrosion-resistant steel
- Swarfless tapping due to rotating punching drill made of stainless steel
- Punched-out pipe piece fits securely and permanent in the drill
- Drill with solid upper and lower stop
- Length of outlet spigot dimensioned for two fusion operations
- Barcode exposed on fast clamping lever RED SNAP for easy scanning with readerwand or barcode scanner
- Installation set DBS is continuously telescopic and self supported in any extended position
- Installation set with a sleeve tube bell with integrated locking function: connects the installation kit firmly to the DAV, unintentional release is prevented
- A foam rubber ring in the sleeve tube bell prevents dirt from penetrating into the installation set

## DAV ACW

### Tapping valve DAV RED SNAP, SDR 11 (closing in an anti-clockwise direction)

- Subsequent tapping with the installation set DBS from the surface box is possible
- High torques can be transferred because of a solid construction