

**\*\*FKM**

Long spigot union for butt welding with seal in EPDM or FKM PN10 SDR 11 - S5.

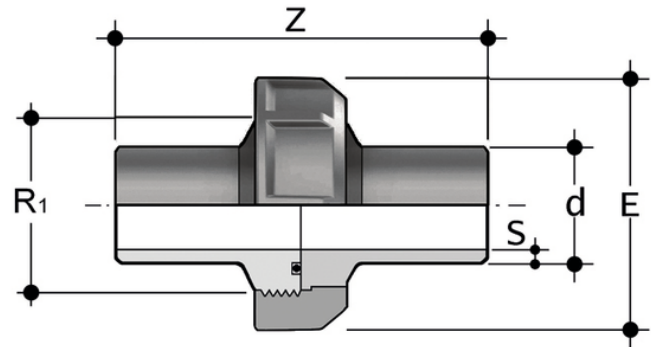
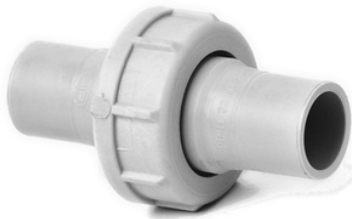

Reference	Other description	system	Category	family	d	DN	R <sub>1</sub>	E	s	Z	g
BBML11020F	* EPDM O-ring ** FKM O-ring	PP-H system	Pressure Fittings	ISO-UNI Fittings Butt Welding	20	15	1"	46	1,9	190	70
BBML11025F	* EPDM O-ring ** FKM O-ring	PP-H system	Pressure Fittings	ISO-UNI Fittings Butt Welding	25	20	1 1/4"	56	2,3	190	105
BBML11032F	* EPDM O-ring ** FKM O-ring	PP-H system	Pressure Fittings	ISO-UNI Fittings Butt Welding	32	25	1 1/2"	66	2,9	190	140
BBML11040F	* EPDM O-ring ** FKM O-ring	PP-H system	Pressure Fittings	ISO-UNI Fittings Butt Welding	40	32	2"	79	3,7	190	210
BBML11050F	* EPDM O-ring ** FKM O-ring	PP-H system	Pressure Fittings	ISO-UNI Fittings Butt Welding	40	50	2 1/4"	87	4,6	190	295
BBML11063F	* EPDM O-ring ** FKM O-ring	PP-H system	Pressure Fittings	ISO-UNI Fittings Butt Welding	63	50	2 3/4"	107	5,8	190	480