

*EPDM

Short spigot union for butt welding with seal in EPDM or FKM PN10 SDR 11 - S5.

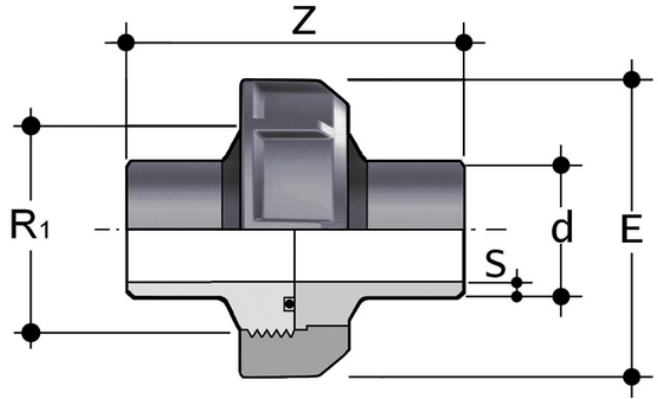

Reference	Other description	system	Category	family	d	DN	E	S	Z	g
BBMC11020E	* EPDM O-ring ** FKM O-ring ***Reduced PN (6 bar), with PVC nut only	PP-H system	Pressure Fittings	ISO-UNI Fittings Butt Welding	20	15	46	1,9	108	80
BBMC11025E	* EPDM O-ring ** FKM O-ring ***Reduced PN (6 bar), with PVC nut only	PP-H system	Pressure Fittings	ISO-UNI Fittings Butt Welding	25	20	56	2,3	108	75
BBMC11032E	* EPDM O-ring ** FKM O-ring ***Reduced PN (6 bar), with PVC nut only	PP-H system	Pressure Fittings	ISO-UNI Fittings Butt Welding	32	25	66	2,9	108	120
BBMC11040E	* EPDM O-ring ** FKM O-ring ***Reduced PN (6 bar), with PVC nut only	PP-H system	Pressure Fittings	ISO-UNI Fittings Butt Welding	40	32	79	3,7	108	175
BBMC11050E	* EPDM O-ring ** FKM O-ring ***Reduced PN (6 bar), with PVC nut only	PP-H system	Pressure Fittings	ISO-UNI Fittings Butt Welding	50	40	87	4,6	108	240
BBMC11063E	* EPDM O-ring ** FKM O-ring ***Reduced PN (6 bar), with PVC nut only	PP-H system	Pressure Fittings	ISO-UNI Fittings Butt Welding	63	50	107	5,8	108	440
BBMC11075E	* EPDM O-ring ** FKM O-ring ***Reduced PN (6 bar), with PVC nut only	PP-H system	Pressure Fittings	ISO-UNI Fittings Butt Welding	***75	65	120	6,8	108	648
BBMC11090E	* EPDM O-ring ** FKM O-ring ***Reduced PN (6 bar), with PVC nut only	PP-H system	Pressure Fittings	ISO-UNI Fittings Butt Welding	***90	80	153	8,2	180	898
BBMC11110E	* EPDM O-ring ** FKM O-ring ***Reduced PN (6 bar), with PVC nut only	PP-H system	Pressure Fittings	ISO-UNI Fittings Butt Welding	***110	100	163	10,0	180	1658