

F/BBE-C - Union bush

Union bush, short spigot, for butt welding SDR 11 - S5.

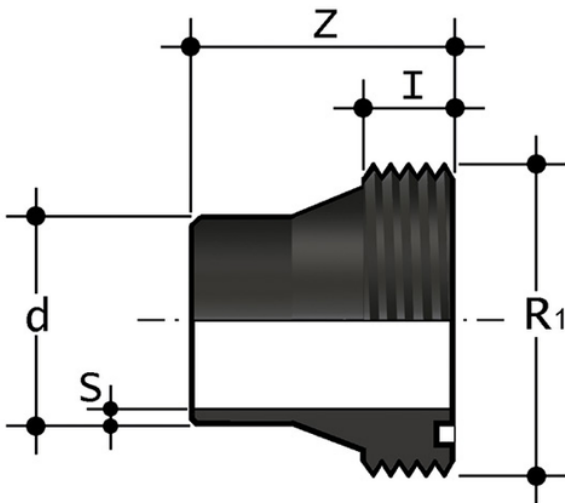

Reference	tooltipImage	system	Category	family	series	d	Z	I	R ₁	S	g
FBBEC11020	-	PE Pipe and Fittings	Pressure Fittings	ISO-UNI Fittings	Short-spigot-for-butt-welding	20	55	13	1"	1,9	13
FBBEC11025	-	PE Pipe and Fittings	Pressure Fittings	ISO-UNI Fittings	Short-spigot-for-butt-welding	25	55	13	1 1/4 "	2,3	29
FBBEC11032	-	PE Pipe and Fittings	Pressure Fittings	ISO-UNI Fittings	Short-spigot-for-butt-welding	32	55	14	1 1/2 "	2,9	42
FBBEC11040	-	PE Pipe and Fittings	Pressure Fittings	ISO-UNI Fittings	Short-spigot-for-butt-welding	40	55	16	2 "	3,7	43
FBBEC11050	-	PE Pipe and Fittings	Pressure Fittings	ISO-UNI Fittings	Short-spigot-for-butt-welding	50	55	18	2 1/4 "	4,6	90
FBBEC11063	-	PE Pipe and Fittings	Pressure Fittings	ISO-UNI Fittings	Short-spigot-for-butt-welding	63	55	20	2 3/4 "	5,8	94

F/BBE-C - Union bush

- Size range: d 12 ÷ d 800 (mm)
- Nominal pressure: SDR 17 (PN10) with water at 20 °C, SDR 11 (PN16) with water at 20 °C
- Temperature range: -40 °C ÷ 60 °C
- Coupling standards - Reference standards:
 - Welding: EN ISO 15494. Can be coupled to pipes according to EN ISO 15494
 - Flanging system: ISO 7005-1, EN 1092-1, EN ISO 15494, ANSI B16.5 cl.150
 - Construction criteria: UNI EN ISO 15494
 - Test methods and requirements: UNI EN ISO 15494
 - Installation criteria: DVS 2202-1, DVS 2207-1, UNI EN 12201- 3, UNI 10520, ISO 21307, UNI 10521, UNI EN 1555-3, ISO 4427- 3, ISO 4437-3
- Fitting material: PE-HD
- Seal material: EPDM, FKM