

GDE SDR17 - 90° elbow

90° elbow, long spigot for butt welding SDR 17 - S 8.

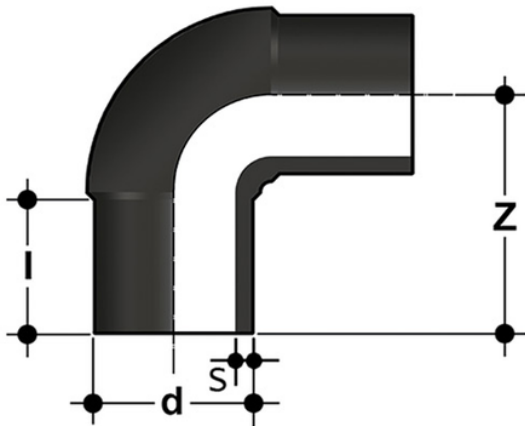

Reference	tooltiplmage	Other description	system	Category	family	series	d	Z	l	S	g
GDE17050	-	* resale products	PE Pipe and Fittings	Pressure Fittings	ISO-UNI Fittings	Long-spigot-for-butt-welding-and-electrofusion	*50	108	80	3,0	105
GDE17063	-	* resale products	PE Pipe and Fittings	Pressure Fittings	ISO-UNI Fittings	Long-spigot-for-butt-welding-and-electrofusion	*63	130	67	3,8	182
GDE17075	-	* resale products	PE Pipe and Fittings	Pressure Fittings	ISO-UNI Fittings	Long-spigot-for-butt-welding-and-electrofusion	*75	153	76	4,5	287
GDE17090	-	* resale products	PE Pipe and Fittings	Pressure Fittings	ISO-UNI Fittings	Long-spigot-for-butt-welding-and-electrofusion	*90	173	83	5,4	465
GDE17110	-	* resale products	PE Pipe and Fittings	Pressure Fittings	ISO-UNI Fittings	Long-spigot-for-butt-welding-and-electrofusion	*110	195	84	6,6	765
GDE17125	-	* resale products	PE Pipe and Fittings	Pressure Fittings	ISO-UNI Fittings	Long-spigot-for-butt-welding-and-electrofusion	*125	216	92	7,4	1030
GDE17140	-	* resale products	PE Pipe and Fittings	Pressure Fittings	ISO-UNI Fittings	Long-spigot-for-butt-welding-and-electrofusion	*140	237	97	8,3	1610
GDE17160	-	* resale products	PE Pipe and Fittings	Pressure Fittings	ISO-UNI Fittings	Long-spigot-for-butt-welding-and-electrofusion	*160	262	103	9,5	2375
GDE17180	-	* resale products	PE Pipe and Fittings	Pressure Fittings	ISO-UNI Fittings	Long-spigot-for-butt-welding-and-electrofusion	*180	290	113	10,7	3035
GDE17200	-	* resale products	PE Pipe and Fittings	Pressure Fittings	ISO-UNI Fittings	Long-spigot-for-butt-welding-and-electrofusion	*200	317	122	11,9	4230
GDE17225	-	* resale products	PE Pipe and Fittings	Pressure Fittings	ISO-UNI Fittings	Long-spigot-for-butt-welding-and-electrofusion	*225	350	130	13,4	5630



GDE SDR17 - 90° elbow

Reference	tooltiplmage	Other description	system	Category	family	series	d	Z	l	S	g
GDE17250	-	* resale products	PE Pipe and Fittings	Pressure Fittings	ISO-UNI Fittings	Long-spigot-for-butt-welding-and-electrofusion	*250	382	134	14,8	7800
GDE17280	-	* resale products	PE Pipe and Fittings	Pressure Fittings	ISO-UNI Fittings	Long-spigot-for-butt-welding-and-electrofusion	*280	430	154	16,6	10670
GDE17315	-	* resale products	PE Pipe and Fittings	Pressure Fittings	ISO-UNI Fittings	Long-spigot-for-butt-welding-and-electrofusion	*315	465	153	18,7	15810



GDE SDR17 – 90° elbow

- Size range: d 12 ÷ d 800 (mm)
- Nominal pressure: SDR 17 (PN10) with water at 20 °C, SDR 11 (PN16) with water at 20 °C
- Temperature range: -40 °C ÷ 60 °C
- Coupling standards – Reference standards:
 - Welding: EN ISO 15494. Can be coupled to pipes according to EN ISO 15494
 - Flanging system: ISO 7005-1, EN 1092-1, EN ISO 15494, ANSI B16.5 cl.150
 - Construction criteria: UNI EN ISO 15494
 - Test methods and requirements: UNI EN ISO 15494
 - Installation criteria: DVS 2202-1, DVS 2207-1, UNI EN 12201- 3, UNI 10520, ISO 21307, UNI 10521, UNI EN 1555-3, ISO 4427- 3, ISO 4437-3
- Fitting material: PE-HD
- Seal material: EPDM, FKM