

# T45DE SDR17 - 45° Tee

90° Tee, long spigot for butt welding SDR 17 - S8.

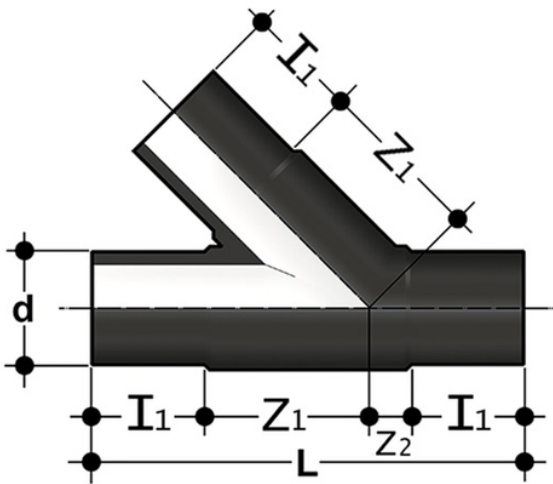

Reference	tooliplmage	Other description	system	Category	family	series	d	L	h <sub>1</sub>	Z <sub>1</sub>	Z <sub>2</sub>	S	g
T45DE17050	-	* resale products	PE Pipe and Fittings	Pressure Fittings	ISO-UNI Fittings	Long-spigot-for-butt-welding-and-electrofusion	*50	223	55	90	23	3,0	200
T45DE17063	-	* resale products	PE Pipe and Fittings	Pressure Fittings	ISO-UNI Fittings	Long-spigot-for-butt-welding-and-electrofusion	*63	256	70	68	24	3,8	410
T45DE17075	-	* resale products	PE Pipe and Fittings	Pressure Fittings	ISO-UNI Fittings	Long-spigot-for-butt-welding-and-electrofusion	*75	299	77	113	32	4,5	690
T45DE17090	-	* resale products	PE Pipe and Fittings	Pressure Fittings	ISO-UNI Fittings	Long-spigot-for-butt-welding-and-electrofusion	*90	354	82	148	42	5,4	1080
T45DE17110	-	* resale products	PE Pipe and Fittings	Pressure Fittings	ISO-UNI Fittings	Long-spigot-for-butt-welding-and-electrofusion	*110	399	90	170	49	6,6	1640
T45DE17125	-	* resale products	PE Pipe and Fittings	Pressure Fittings	ISO-UNI Fittings	Long-spigot-for-butt-welding-and-electrofusion	*125	440	93	204	47	7,4	2665
T45DE17160	-	* resale products	PE Pipe and Fittings	Pressure Fittings	ISO-UNI Fittings	Long-spigot-for-butt-welding-and-electrofusion	*160	521	98	262	68	9,5	4820
T45DE17180	-	* resale products	PE Pipe and Fittings	Pressure Fittings	ISO-UNI Fittings	Long-spigot-for-butt-welding-and-electrofusion	*180	557	105	275	74	10,7	6440



# T45DE SDR17 - 45° Tee

Reference	tooltipImage	Other description	system	Category	family	series	d	L	h <sub>1</sub>	Z <sub>1</sub>	Z <sub>2</sub>	S	g
T45DE17200	-	* resale products	PE Pipe and Fittings	Pressure Fittings	ISO-UNI Fittings	Long-spigot-for-butt-welding-and-electrofusion	*200	598	113	294	78	11,9	8420
T45DE17225	-	* resale products	PE Pipe and Fittings	Pressure Fittings	ISO-UNI Fittings	Long-spigot-for-butt-welding-and-electrofusion	*225	670	120	344	86	13,4	11980



## T45DE SDR17 - 45° Tee

- Size range:  $d 12 \div d 800$  (mm)
- Nominal pressure: SDR 17 (PN10) with water at 20 °C, SDR 11 (PN16) with water at 20 °C
- Temperature range:  $-40 \text{ °C} \div 60 \text{ °C}$
- Coupling standards - Reference standards:
  - Welding: EN ISO 15494. Can be coupled to pipes according to EN ISO 15494
  - Flanging system: ISO 7005-1, EN 1092-1, EN ISO 15494, ANSI B16.5 cl.150
  - Construction criteria: UNI EN ISO 15494
  - Test methods and requirements: UNI EN ISO 15494
  - Installation criteria: DVS 2202-1, DVS 2207-1, UNI EN 12201- 3, UNI 10520, ISO 21307, UNI 10521, UNI EN 1555-3, ISO 4427- 3, ISO 4437-3
- Fitting material: PE-HD
- Seal material: EPDM, FKM