

TRDE SDR11 - 90° reduced tee

90° reduced tee, long spigot for butt welding SDR 11 - S5.

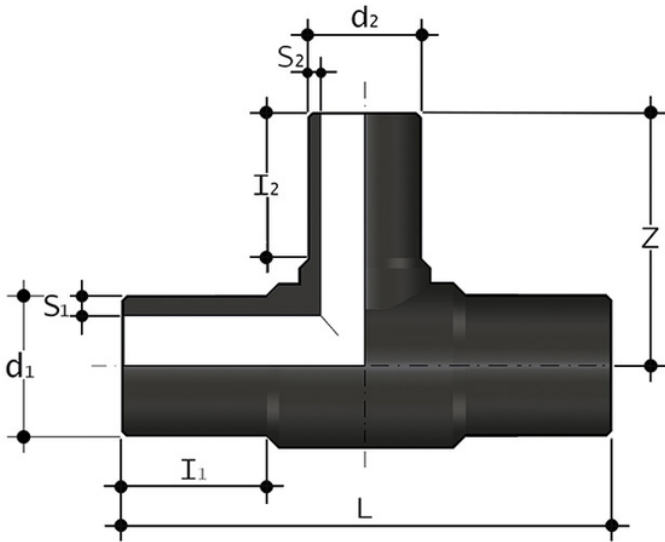

Reference	tootiplmage	Other description	system	Category	family	series	d ₁	d ₂	L	Z	h ₁	h ₂	S ₁	S ₂	g
TRDE11063050	-	* resale products	PE Pipe and Fittings	Pressure Fittings	ISO-UNI Fittings	Long-spigot-for-butt-welding-and-electrofusion	*63	50	215	103	63	56	5,8	4,6	313
TRDE11075032	-	* resale products	PE Pipe and Fittings	Pressure Fittings	ISO-UNI Fittings	Long-spigot-for-butt-welding-and-electrofusion	*75	32	256	108	70	46	6,8	2,9	455
TRDE11075050	-	* resale products	PE Pipe and Fittings	Pressure Fittings	ISO-UNI Fittings	Long-spigot-for-butt-welding-and-electrofusion	*75	50	253	113	70	56	6,8	4,6	485
TRDE11075063	-	* resale products	PE Pipe and Fittings	Pressure Fittings	ISO-UNI Fittings	Long-spigot-for-butt-welding-and-electrofusion	*75	63	255	117	70	63	6,8	5,8	520
TRDE11090063	-	* resale products	PE Pipe and Fittings	Pressure Fittings	ISO-UNI Fittings	Long-spigot-for-butt-welding-and-electrofusion	*90	63	282	127	81	65	8,2	5,8	840

TRDE SDR11 - 90° reduced tee

Reference	tooltiplmage	Other description	system	Category	family	series	d ₁	d ₂	L	Z	h ₁	h ₂	S ₁	S ₂	g
TRDE11090075	-	* resale products	PE Pipe and Fittings	Pressure Fittings	ISO-UNI Fittings	Long-spigot-for-butt-welding-and-electrofusion	*90	75	272	138	73	68	8,2	6,8	800
TRDE11110063	-	* resale products	PE Pipe and Fittings	Pressure Fittings	ISO-UNI Fittings	Long-spigot-for-butt-welding-and-electrofusion	*110	63	322	148	88	67	10,0	5,8	1400
TRDE11110075	-	* resale products	PE Pipe and Fittings	Pressure Fittings	ISO-UNI Fittings	Long-spigot-for-butt-welding-and-electrofusion	*110	75	309	151	82	70	10,0	6,8	1425
TRDE11110090	-	* resale products	PE Pipe and Fittings	Pressure Fittings	ISO-UNI Fittings	Long-spigot-for-butt-welding-and-electrofusion	*110	90	322	164	88	82	10,0	8,2	1495
TRDE11125075	-	* resale products	PE Pipe and Fittings	Pressure Fittings	ISO-UNI Fittings	Long-spigot-for-butt-welding-and-electrofusion	*125	75	350	170	110	75	11,4	6,8	1820
TRDE11125090	-	* resale products	PE Pipe and Fittings	Pressure Fittings	ISO-UNI Fittings	Long-spigot-for-butt-welding-and-electrofusion	*125	90	332	168	109	89	11,4	8,2	1700
TRDE11125110	-	* resale products	PE Pipe and Fittings	Pressure Fittings	ISO-UNI Fittings	Long-spigot-for-butt-welding-and-electrofusion	*125	110	341	170	90	83	11,4	10,0	1860
TRDE11160063	-	* resale products	PE Pipe and Fittings	Pressure Fittings	ISO-UNI Fittings	Long-spigot-for-butt-welding-and-electrofusion	*160	63	416	174	105	65	14,6	5,8	3605
TRDE11160075	-	* resale products	PE Pipe and Fittings	Pressure Fittings	ISO-UNI Fittings	Long-spigot-for-butt-welding-and-electrofusion	*160	75	343	180	98	74	14,6	6,8	2300
TRDE11160090	-	* resale products	PE Pipe and Fittings	Pressure Fittings	ISO-UNI Fittings	Long-spigot-for-butt-welding-and-electrofusion	*160	90	415	190	104	83	14,6	8,2	3690



TRDE SDR11 - 90° reduced tee

Reference	tooltiplmage	Other description	system	Category	family	series	d ₁	d ₂	L	Z	h ₁	h ₂	S ₁	S ₂	g
TRDE11160110	-	* resale products	PE Pipe and Fittings	Pressure Fittings	ISO-UNI Fittings	Long-spigot-for-butt-welding-and-electrofusion	*160	110	414	200	104	89	14,6	10,0	3865
TRDE11180090	-	* resale products	PE Pipe and Fittings	Pressure Fittings	ISO-UNI Fittings	Long-spigot-for-butt-welding-and-electrofusion	*180	90	476	200	108	82	16,4	8,2	4857
TRDE11180110	-	* resale products	PE Pipe and Fittings	Pressure Fittings	ISO-UNI Fittings	Long-spigot-for-butt-welding-and-electrofusion	*180	110	480	202	107	84	16,4	10,0	4750
TRDE11180160	-	* resale products	PE Pipe and Fittings	Pressure Fittings	ISO-UNI Fittings	Long-spigot-for-butt-welding-and-electrofusion	*180	160	480	220	110	101	16,4	14,6	5560
TRDE11200063	-	* resale products	PE Pipe and Fittings	Pressure Fittings	ISO-UNI Fittings	Long-spigot-for-butt-welding-and-electrofusion	*200	63	553	226	134	82	18,2	5,8	7140
TRDE11200090	-	* resale products	PE Pipe and Fittings	Pressure Fittings	ISO-UNI Fittings	Long-spigot-for-butt-welding-and-electrofusion	*200	90	500	216	124	82	18,2	8,2	6895
TRDE11200110	-	* resale products	PE Pipe and Fittings	Pressure Fittings	ISO-UNI Fittings	Long-spigot-for-butt-welding-and-electrofusion	*200	110	505	219	124	86	18,2	10,0	7060
TRDE11200160	-	* resale products	PE Pipe and Fittings	Pressure Fittings	ISO-UNI Fittings	Long-spigot-for-butt-welding-and-electrofusion	*200	160	500	237	120	101	18,2	14,6	7445
TRDE11225075	-	* resale products	PE Pipe and Fittings	Pressure Fittings	ISO-UNI Fittings	Long-spigot-for-butt-welding-and-electrofusion	*225	75	560	219	129	73	20,5	6,8	9750
TRDE11225090	-	* resale products	PE Pipe and Fittings	Pressure Fittings	ISO-UNI Fittings	Long-spigot-for-butt-welding-and-electrofusion	*225	90	555	228	129	82	20,5	8,2	9850



TRDE SDR11 - 90° reduced tee

Reference	tooltiplmage	Other description	system	Category	family	series	d ₁	d ₂	L	Z	h ₁	h ₂	S ₁	S ₂	g
TRDE11225110	-	* resale products	PE Pipe and Fittings	Pressure Fittings	ISO-UNI Fittings	Long-spigot-for-butt-welding-and-electrofusion	*225	110	559	238	130	86	20,5	10,0	10100
TRDE11225160	-	* resale products	PE Pipe and Fittings	Pressure Fittings	ISO-UNI Fittings	Long-spigot-for-butt-welding-and-electrofusion	*225	160	556	258	128	107	20,5	14,6	10485
TRDE11225180	-	* resale products	PE Pipe and Fittings	Pressure Fittings	ISO-UNI Fittings	Long-spigot-for-butt-welding-and-electrofusion	*225	180	559	284	130	108	20,5	16,4	10915
TRDE11250110	-	* resale products	PE Pipe and Fittings	Pressure Fittings	ISO-UNI Fittings	Long-spigot-for-butt-welding-and-electrofusion	*250	110	584	248	133	85	22,7	10,0	11685
TRDE11250160	-	* resale products	PE Pipe and Fittings	Pressure Fittings	ISO-UNI Fittings	Long-spigot-for-butt-welding-and-electrofusion	*250	160	586	266	134	102	22,7	14,6	12180
TRDE11315110	-	* resale products	PE Pipe and Fittings	Pressure Fittings	ISO-UNI Fittings	Long-spigot-for-butt-welding-and-electrofusion	*315	110	706	282	155	85	28,6	10,0	22150
TRDE11315160	-	* resale products	PE Pipe and Fittings	Pressure Fittings	ISO-UNI Fittings	Long-spigot-for-butt-welding-and-electrofusion	*315	160	705	301	155	101	28,6	14,6	22730
TRDE11315200	-	* resale products	PE Pipe and Fittings	Pressure Fittings	ISO-UNI Fittings	Long-spigot-for-butt-welding-and-electrofusion	*315	200	680	313	155	117	28,6	18,2	18710
TRDE11315225	-	* resale products	PE Pipe and Fittings	Pressure Fittings	ISO-UNI Fittings	Long-spigot-for-butt-welding-and-electrofusion	*315	225	690	320	153	125	28,6	20,5	20160
TRDE11315250	-	* resale products	PE Pipe and Fittings	Pressure Fittings	ISO-UNI Fittings	Long-spigot-for-butt-welding-and-electrofusion	*315	250	695	331	154	135	28,6	22,7	24345

TRDE SDR11 – 90° reduced tee

- Size range: d 12 ÷ d 800 (mm)
- Nominal pressure: SDR 17 (PN10) with water at 20 °C, SDR 11 (PN16) with water at 20 °C
- Temperature range: -40 °C ÷ 60 °C
- Coupling standards – Reference standards:
 - Welding: EN ISO 15494. Can be coupled to pipes according to EN ISO 15494
 - Flanging system: ISO 7005-1, EN 1092-1, EN ISO 15494, ANSI B16.5 cl.150
 - Construction criteria: UNI EN ISO 15494
 - Test methods and requirements: UNI EN ISO 15494
 - Installation criteria: DVS 2202-1, DVS 2207-1, UNI EN 12201- 3, UNI 10520, ISO 21307, UNI 10521, UNI EN 1555-3, ISO 4427- 3, ISO 4437-3
- Fitting material: PE-HD
- Seal material: EPDM, FKM