

RDE SDR17 - Concentric reducer

Concentric reducer, long spigot for butt welding SDR 17 - S8.

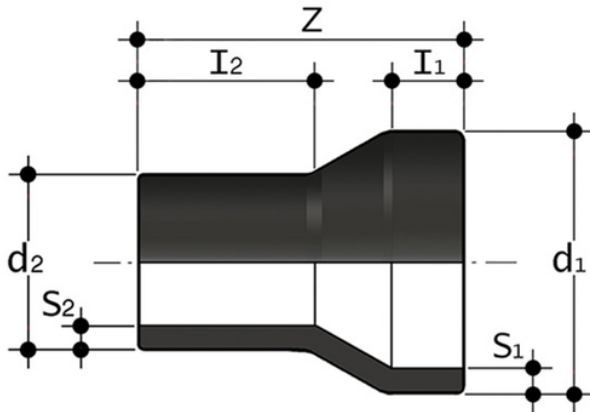

Reference	Other description	system	Category	family	series	d ₁	d ₂	Z	l ₁	l ₂	S ₁	S ₂	g
RDE17063050	* resale products	PE Pipe and Fittings	Pressure Fittings	ISO-UNI Fittings	Long-spigot-for-butt-welding-and-electrofusion	*63	50	152	64	58	3,8	3,0	95
RDE17075063	* resale products	PE Pipe and Fittings	Pressure Fittings	ISO-UNI Fittings	Long-spigot-for-butt-welding-and-electrofusion	*75	63	166	80	63	4,5	3,8	150
RDE17090063	* resale products	PE Pipe and Fittings	Pressure Fittings	ISO-UNI Fittings	Long-spigot-for-butt-welding-and-electrofusion	*90	63	182	79	63	5,4	3,8	215
RDE17090075	* resale products	PE Pipe and Fittings	Pressure Fittings	ISO-UNI Fittings	Long-spigot-for-butt-welding-and-electrofusion	*90	75	185	80	63	5,4	4,5	236
RDE17110063	* resale products	PE Pipe and Fittings	Pressure Fittings	ISO-UNI Fittings	Long-spigot-for-butt-welding-and-electrofusion	*110	63	185	84	69	6,6	3,8	295
RDE17110075	* resale products	PE Pipe and Fittings	Pressure Fittings	ISO-UNI Fittings	Long-spigot-for-butt-welding-and-electrofusion	*110	75	183	83	73	6,6	4,5	315
RDE17110090	* resale products	PE Pipe and Fittings	Pressure Fittings	ISO-UNI Fittings	Long-spigot-for-butt-welding-and-electrofusion	*110	90	185	83	80	6,6	5,4	335
RDE17125063	* resale products	PE Pipe and Fittings	Pressure Fittings	ISO-UNI Fittings	Long-spigot-for-butt-welding-and-electrofusion	*125	63	200	90	68	7,4	3,8	450

RDE SDR17 - Concentric reducer

Reference	Other description	system	Category	family	series	d ₁	d ₂	Z	h ₁	h ₂	S ₁	S ₂	g
RDE17125090	* resale products	PE Pipe and Fittings	Pressure Fittings	ISO-UNI Fittings	Long-spigot-for-butt-welding-and-electrofusion	*125	90	200	90	81	7,4	5,4	460
RDE17125110	* resale products	PE Pipe and Fittings	Pressure Fittings	ISO-UNI Fittings	Long-spigot-for-butt-welding-and-electrofusion	*125	110	200	91	90	7,4	6,6	500
RDE17140090	* resale products	PE Pipe and Fittings	Pressure Fittings	ISO-UNI Fittings	Long-spigot-for-butt-welding-and-electrofusion	*140	90	235	112	86	8,3	5,4	630
RDE17140110	* resale products	PE Pipe and Fittings	Pressure Fittings	ISO-UNI Fittings	Long-spigot-for-butt-welding-and-electrofusion	*140	110	237	114	91	8,3	6,6	695
RDE17140125	* resale products	PE Pipe and Fittings	Pressure Fittings	ISO-UNI Fittings	Long-spigot-for-butt-welding-and-electrofusion	*140	125	235	117	96	8,3	7,4	740
RDE17160090	* resale products	PE Pipe and Fittings	Pressure Fittings	ISO-UNI Fittings	Long-spigot-for-butt-welding-and-electrofusion	*160	90	254	109	84	9,5	5,4	820
RDE17160110	* resale products	PE Pipe and Fittings	Pressure Fittings	ISO-UNI Fittings	Long-spigot-for-butt-welding-and-electrofusion	*160	110	254	110	89	9,5	6,6	890
RDE17160125	* resale products	PE Pipe and Fittings	Pressure Fittings	ISO-UNI Fittings	Long-spigot-for-butt-welding-and-electrofusion	*160	125	254	110	95	9,5	7,4	960
RDE17160140	* resale products	PE Pipe and Fittings	Pressure Fittings	ISO-UNI Fittings	Long-spigot-for-butt-welding-and-electrofusion	*160	140	254	110	106	9,5	8,3	1010
RDE17180125	* resale products	PE Pipe and Fittings	Pressure Fittings	ISO-UNI Fittings	Long-spigot-for-butt-welding-and-electrofusion	*180	125	250	105	87	10,7	7,4	1145
RDE17180140	* resale products	PE Pipe and Fittings	Pressure Fittings	ISO-UNI Fittings	Long-spigot-for-butt-welding-and-electrofusion	*180	140	277	123	114	10,7	8,3	1305
RDE17180160	* resale products	PE Pipe and Fittings	Pressure Fittings	ISO-UNI Fittings	Long-spigot-for-butt-welding-and-electrofusion	*180	160	279	126	125	10,7	9,5	1450
RDE17200140	* resale products	PE Pipe and Fittings	Pressure Fittings	ISO-UNI Fittings	Long-spigot-for-butt-welding-and-electrofusion	*200	140	279	123	114	11,9	8,3	1590
RDE17200160	* resale products	PE Pipe and Fittings	Pressure Fittings	ISO-UNI Fittings	Long-spigot-for-butt-welding-and-electrofusion	*200	160	278	122	124	11,9	9,5	1655
RDE17225140	* resale products	PE Pipe and Fittings	Pressure Fittings	ISO-UNI Fittings	Long-spigot-for-butt-welding-and-electrofusion	*225	140	290	133	114	13,4	8,3	1980



RDE SDR17 - Concentric reducer

Reference	Other description	system	Category	family	series	d ₁	d ₂	Z	h ₁	h ₂	S ₁	S ₂	g
RDE17225160	* resale products	PE Pipe and Fittings	Pressure Fittings	ISO-UNI Fittings	Long-spigot-for-butt-welding-and-electrofusion	*225	160	295	134	123	13,4	9,5	2175
RDE17225180	* resale products	PE Pipe and Fittings	Pressure Fittings	ISO-UNI Fittings	Long-spigot-for-butt-welding-and-electrofusion	*225	180	275	125	118	13,4	10,7	2145
RDE17250160	* resale products	PE Pipe and Fittings	Pressure Fittings	ISO-UNI Fittings	Long-spigot-for-butt-welding-and-electrofusion	*250	160	308	151	98	14,8	9,5	2850
RDE17250180	* resale products	PE Pipe and Fittings	Pressure Fittings	ISO-UNI Fittings	Long-spigot-for-butt-welding-and-electrofusion	*250	180	316	153	105	14,8	10,7	2850
RDE17250200	* resale products	PE Pipe and Fittings	Pressure Fittings	ISO-UNI Fittings	Long-spigot-for-butt-welding-and-electrofusion	*250	200	325	154	113	14,8	11,9	3205
RDE17250225	* resale products	PE Pipe and Fittings	Pressure Fittings	ISO-UNI Fittings	Long-spigot-for-butt-welding-and-electrofusion	*250	225	330	155	122	14,8	13,4	3550
RDE17280200	* resale products	PE Pipe and Fittings	Pressure Fittings	ISO-UNI Fittings	Long-spigot-for-butt-welding-and-electrofusion	*280	200	330	142	116	16,6	11,9	3880
RDE17280225	* resale products	PE Pipe and Fittings	Pressure Fittings	ISO-UNI Fittings	Long-spigot-for-butt-welding-and-electrofusion	*280	225	335	140	124	16,6	13,4	4100
RDE17280250	* resale products	PE Pipe and Fittings	Pressure Fittings	ISO-UNI Fittings	Long-spigot-for-butt-welding-and-electrofusion	*280	250	340	139	134	16,6	14,8	4420
RDE17315200	* resale products	PE Pipe and Fittings	Pressure Fittings	ISO-UNI Fittings	Long-spigot-for-butt-welding-and-electrofusion	*315	200	380	180	134	18,7	11,9	5400
RDE17315225	* resale products	PE Pipe and Fittings	Pressure Fittings	ISO-UNI Fittings	Long-spigot-for-butt-welding-and-electrofusion	*315	225	371	152	125	18,7	13,4	5290
RDE17315250	* resale products	PE Pipe and Fittings	Pressure Fittings	ISO-UNI Fittings	Long-spigot-for-butt-welding-and-electrofusion	*315	250	367	151	133	18,7	14,8	5635
RDE17315280	* resale products	PE Pipe and Fittings	Pressure Fittings	ISO-UNI Fittings	Long-spigot-for-butt-welding-and-electrofusion	*315	280	369	150	140	18,7	16,6	5950
RDE17355250	* resale products	PE Pipe and Fittings	Pressure Fittings	ISO-UNI Fittings	Long-spigot-for-butt-welding-and-electrofusion	*355	250	390	164	129	21,1	14,8	7200
RDE17355280	* resale products	PE Pipe and Fittings	Pressure Fittings	ISO-UNI Fittings	Long-spigot-for-butt-welding-and-electrofusion	*355	280	390	164	139	21,1	16,6	9000





RDE SDR17 - Concentric reducer

Reference	Other description	system	Category	family	series	d ₁	d ₂	Z	h ₁	h ₂	S ₁	S ₂	g
RDE17355315	* resale products	PE Pipe and Fittings	Pressure Fittings	ISO-UNI Fittings	Long-spigot-for-butt-welding-and-electrofusion	*355	315	340	164	150	21,1	18,7	10000
RDE17400280	* resale products	PE Pipe and Fittings	Pressure Fittings	ISO-UNI Fittings	Long-spigot-for-butt-welding-and-electrofusion	*400	280	415	179	139	23,7	16,6	13500
RDE17400315	* resale products	PE Pipe and Fittings	Pressure Fittings	ISO-UNI Fittings	Long-spigot-for-butt-welding-and-electrofusion	*400	315	415	179	150	23,7	18,7	13060
RDE17400355	* resale products	PE Pipe and Fittings	Pressure Fittings	ISO-UNI Fittings	Long-spigot-for-butt-welding-and-electrofusion	*400	355	420	179	164	23,7	21,1	15000
RDE17450315	* resale products	PE Pipe and Fittings	Pressure Fittings	ISO-UNI Fittings	Long-spigot-for-butt-welding-and-electrofusion	*450	315	390	195	150	26,7	18,7	11600
RDE17450355	* resale products	PE Pipe and Fittings	Pressure Fittings	ISO-UNI Fittings	Long-spigot-for-butt-welding-and-electrofusion	*450	355	395	195	165	26,7	21,1	11900
RDE17450400	* resale products	PE Pipe and Fittings	Pressure Fittings	ISO-UNI Fittings	Long-spigot-for-butt-welding-and-electrofusion	*450	400	400	205	180	26,7	23,7	12700
RDE17500315	* resale products	PE Pipe and Fittings	Pressure Fittings	ISO-UNI Fittings	Long-spigot-for-butt-welding-and-electrofusion	*500	315	425	212	150	29,7	18,7	15500
RDE17500355	* resale products	PE Pipe and Fittings	Pressure Fittings	ISO-UNI Fittings	Long-spigot-for-butt-welding-and-electrofusion	*500	355	430	225	165	29,7	21,1	15700
RDE17500400	* resale products	PE Pipe and Fittings	Pressure Fittings	ISO-UNI Fittings	Long-spigot-for-butt-welding-and-electrofusion	*500	400	430	225	180	29,7	23,7	16200
RDE17500450	* resale products	PE Pipe and Fittings	Pressure Fittings	ISO-UNI Fittings	Long-spigot-for-butt-welding-and-electrofusion	*500	450	430	225	195	29,7	26,7	17000
RDE17560355	* resale products	PE Pipe and Fittings	Pressure Fittings	ISO-UNI Fittings	Long-spigot-for-butt-welding-and-electrofusion	*560	355	460	240	165	33,2	21,1	21400
RDE17560400	* resale products	PE Pipe and Fittings	Pressure Fittings	ISO-UNI Fittings	Long-spigot-for-butt-welding-and-electrofusion	*560	400	470	240	180	33,2	23,7	21700
RDE17560450	* resale products	PE Pipe and Fittings	Pressure Fittings	ISO-UNI Fittings	Long-spigot-for-butt-welding-and-electrofusion	*560	450	470	240	195	33,2	26,7	22300
RDE17560500	* resale products	PE Pipe and Fittings	Pressure Fittings	ISO-UNI Fittings	Long-spigot-for-butt-welding-and-electrofusion	*560	500	470	240	215	33,2	29,7	23200



RDE SDR17 - Concentric reducer

Reference	Other description	system	Category	family	series	d ₁	d ₂	Z	h ₁	h ₂	S ₁	S ₂	g
RDE17630400	* resale products	PE Pipe and Fittings	Pressure Fittings	ISO-UNI Fittings	Long-spigot-for-butt-welding-and-electrofusion	*630	400	510	260	180	37,4	23,7	29700
RDE17630450	* resale products	PE Pipe and Fittings	Pressure Fittings	ISO-UNI Fittings	Long-spigot-for-butt-welding-and-electrofusion	*630	450	510	260	195	37,4	26,7	30100
RDE17630500	* resale products	PE Pipe and Fittings	Pressure Fittings	ISO-UNI Fittings	Long-spigot-for-butt-welding-and-electrofusion	*630	500	510	260	215	37,4	29,7	30800
RDE17630560	* resale products	PE Pipe and Fittings	Pressure Fittings	ISO-UNI Fittings	Long-spigot-for-butt-welding-and-electrofusion	*630	560	520	260	235	37,4	33,2	31900

RDE SDR17 – Concentric reducer

- Size range: d 12 ÷ d 800 (mm)
- Nominal pressure: SDR 17 (PN10) with water at 20 °C, SDR 11 (PN16) with water at 20 °C
- Temperature range: -40 °C ÷ 60 °C
- Coupling standards – Reference standards:
 - Welding: EN ISO 15494. Can be coupled to pipes according to EN ISO 15494
 - Flanging system: ISO 7005-1, EN 1092-1, EN ISO 15494, ANSI B16.5 cl.150
 - Construction criteria: UNI EN ISO 15494
 - Test methods and requirements: UNI EN ISO 15494
 - Installation criteria: DVS 2202-1, DVS 2207-1, UNI EN 12201- 3, UNI 10520, ISO 21307, UNI 10521, UNI EN 1555-3, ISO 4427- 3, ISO 4437-3
- Fitting material: PE-HD
- Seal material: EPDM, FKM