

# UAN

## Universal adaptor HD-PE/brass with male thread and PE pipe socket

Universal transition adaptor brass pipe UAN

- Water and gas
- Working pressure: MOP (gas) 5 bar, PFA (water) 16 bar
- Material: PE 100 and brass [CW617N / CW612N, ISO 228 thread]

### Note:

The brass side is anchored non-detachable and non-rotatable in the PE.

Installation independent of position possible.

For use in the water and gas sector.

Other thread dimensions and materials on request.

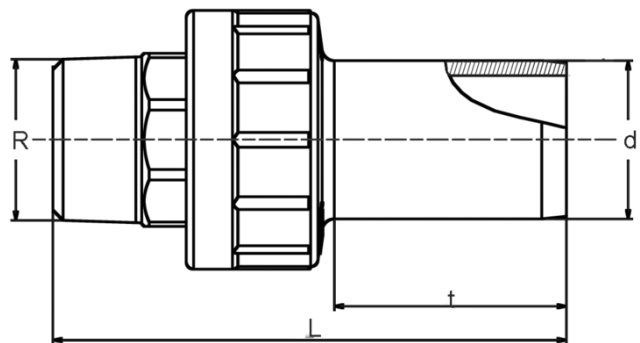

**UAN**

## Universal adaptor HD-PE/brass with male thread and PE pipe socket

### Areas of Application

The FRIALEN Universal Adapter UAN serves to connect metal construction parts which have a screwed connection e.g. valves with an HD-PE connection pipe. Suitable for gas and water supply or for industrial applications. The version with PE spigot end allows for assembly regardless of location and the homogenous fusion connection with all suitable FRIALEN fittings (exception of FRIALONG- and FRIASTOPP-Long couplers).

The threaded joint is according ISO 7-1.

### Assembly Instructions

Usually the screw connection needs to be assembled first as assembly related torsion forces should not bear down on the connected PE pipe. The tightening forces must be introduced via the specially designed wrench area.

The fusion of the PE spigot end with a FRIALEN coupler takes place by using FRIALEN fusion process – leakproof and longitudinally strong.

The installation is according to the general installation instruction (see "Transition Fittings with threaded connection" in "Assembly Instructions" for "FRIALEN-Safety Fittings for house connections and distribution pipes up to d 225"). This involves removing the oxide layer and cleaning the pipe ends.

### Good reasons for using the FRIALEN-Universal Adapter UAN:

- PE 100 spigot end – quality controlled
- Tested and quality controlled brass quality
- Assembly regardless of location, high degree of flexibility due to separate fusion of PE spigot end
- May be used with all FRIALEN fittings of identical dimensions (exception of FRIALONG- and FRIASTOPP-Long couplers)
- Universal combination option with the FRIALEN range
- HD-PE side with spigot end for processing without holding device, designed for FRIALEN couplers
- Pull-proof connection
- Brass side tightly connected with PE spigot end, safe from distortion
- Compact construction
- Additional barcode for tracing back the fitting (Traceability-Coding)
- Oxidic layer may be removed from PE spigot end using scraper tools