

Expansion joint – horizontal M/F

- EN 1329 Solvent Welded PVC-U Fittings
- B s2 d0 Fire Reaction Euroclass
- Color: RAL 7037 Grey

In branches or bends, the most correct technical solution is inserting a horizontal expansion joint into the piping whenever the section between two fixed points is higher than 2÷3 m, and always when connecting washing-machines, dishwashers and kitchen sinks.

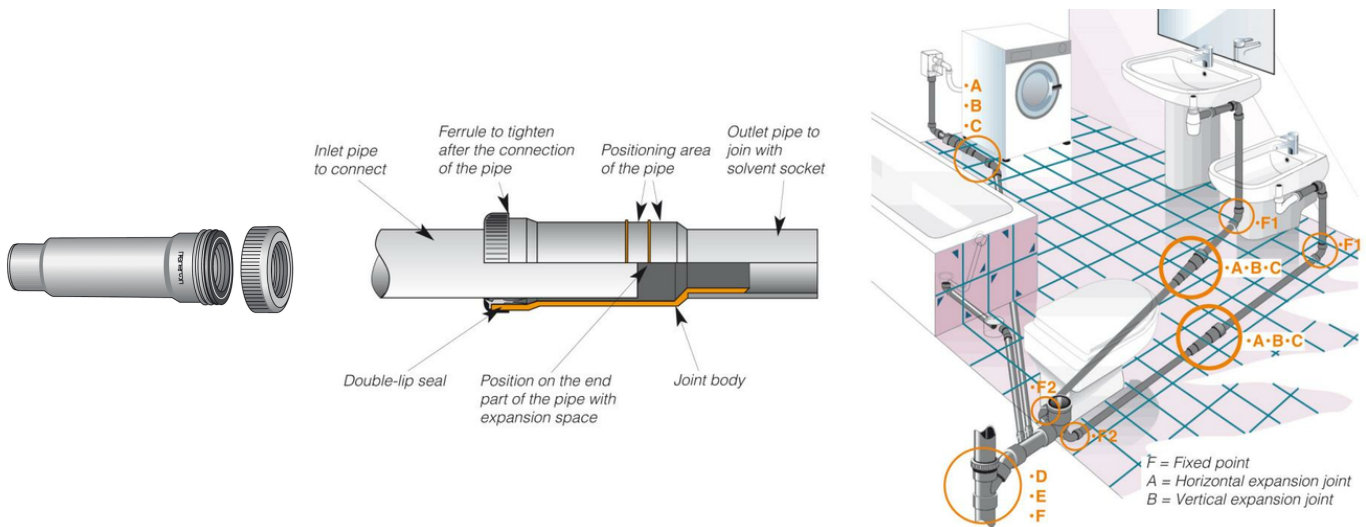

Reference	tooltiplmage	DN (mm)	Version
1290302	-	32	-
1290402	-	40	-
1290502	-	50	-
MLH00NI	-	63	-
MPH00NI	-	75	upon request
MRH00NI	-	80	-
MTH00NI	-	100	-
MVH00NI	-	110	-
MXH00NI	-	125	-
MZH00NI	-	160	-