

SUPER PLUS, activated sludge system

One-piece polyethylene packaged

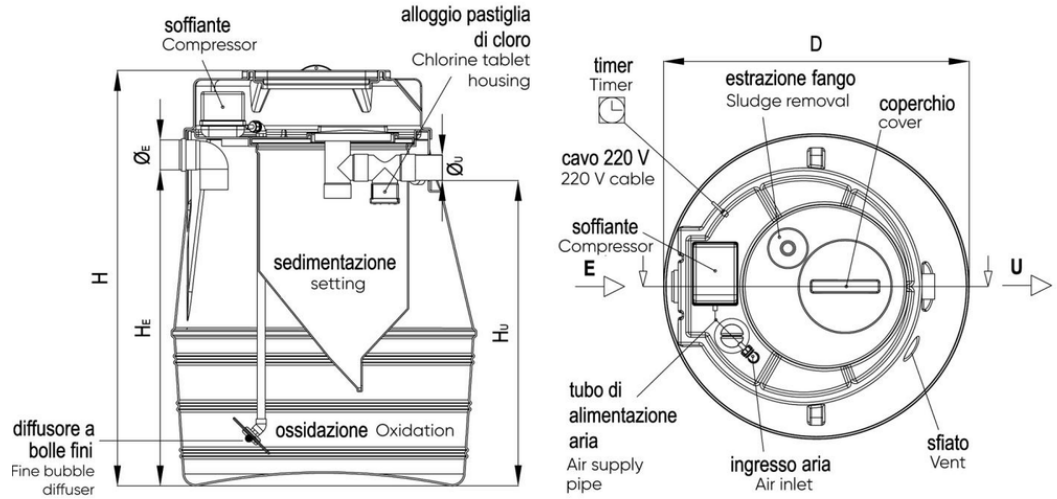

Reference	tooltiplmage	D (cm)	Height H (cm)	HE (cm)	HU (cm)	V ox (m ³)	V sett (m ³)	ØE e ØU (mm)	Power (Kw)	Item	Users (E.I.)
ISO9220	-	120	142	105	100	0,73	0,17	100	30 (W)	SUPER PLUS S.1	5
ISO9221	-	120	162	125	120	1,14	0,25	100	40 (W)	SUPER PLUS S.2	10
ISO9222	-	120	202	165	160	1,44	0,5	125	40 (W)	SUPER PLUS S.3	15
ISO9223	-	160	187	140	135	2,47	0,5	140	45 (W)	SUPER PLUS S.4	20
ISO9224	-	160	222	175	170	3,47	0,6	140	50 (W)	SUPER PLUS S.5	25