

# SRIM - Ball check valve DN 15:50

Ball check valve with ends for socket welding, metric series.

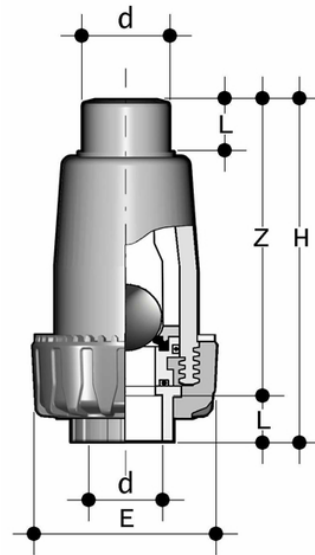

Reference	tooltiplimage	system	Category	family	series	d	DN	PN	E	H	L	Z	g
SRIM020F	-	PP-H system	Manual valves	Auxiliary valves	SR DN 15÷50	20	15	10	55	105	16	89	75
SRIM025F	-	PP-H system	Manual valves	Auxiliary valves	SR DN 15÷50	25	20	10	66	126	19	107	140
SRIM032F	-	PP-H system	Manual valves	Auxiliary valves	SR DN 15÷50	32	25	10	74	148	22	126	215
SRIM040F	-	PP-H system	Manual valves	Auxiliary valves	SR DN 15÷50	40	32	10	86	172	26	146	320
SRIM050F	-	PP-H system	Manual valves	Auxiliary valves	SR DN 15÷50	50	40	10	99	189	31	158	440
SRIM063F	-	PP-H system	Manual valves	Auxiliary valves	SR DN 15÷50	63	50	10	120	224	38	186	750



## SRIM – Ball check valve DN 15:50

- Connection system for weld joints
- PN10 **valve body made for PP-H injection moulding** and European Directive 2014/68/EU (PED) compliant for pressurised equipment. ISO 9393 compliant test requirements
- The valve can only be used with fluids with specific weight under 1,20 g/cm<sup>3</sup>
- **Sealing system with antiblow out design**
- Ball entirely in talc-filled PP
- Can be maintained with the valve body installed
- Can be **installed** in either a **vertical** (preferable) or **horizontal position**