

SRIF – Ball check valve DN 15:50

Ball check valve with ends for socket welding, metric series.

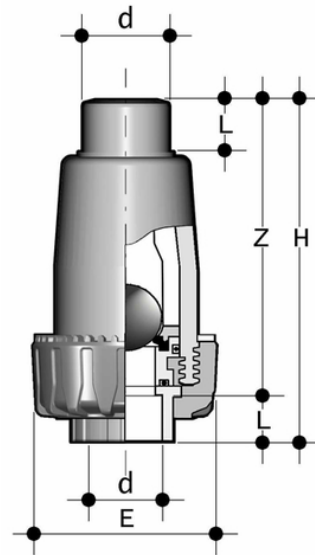

Reference	tooltiplmage	system	Category	family	series	d	DN	PN	E	H	L	Z	g
SRIF020F	-	PVDF system	Manual valves	Auxiliary valves	SR DN 15÷50	20	15	16	54	104	16	88	150
SRIF025F	-	PVDF system	Manual valves	Auxiliary valves	SR DN 15÷50	25	20	16	65	125	19	106	260
SRIF032F	-	PVDF system	Manual valves	Auxiliary valves	SR DN 15÷50	32	25	16	74	148	22	126	390
SRIF040F	-	PVDF system	Manual valves	Auxiliary valves	SR DN 15÷50	40	32	16	86	171	26	145	600
SRIF050F	-	PVDF system	Manual valves	Auxiliary valves	SR DN 15÷50	50	40	16	98	189	31	158	820
SRIF063F	-	PVDF system	Manual valves	Auxiliary valves	SR DN 15÷50	63	50	16	119	222	38	184	1420



SRIF – Ball check valve DN 15:50

- Connection system for weld joints
- PN10 **valve body made for PP-H injection moulding** and European Directive 2014/68/EU (PED) compliant for pressurised equipment. ISO 9393 compliant test requirements
- The valve can only be used with fluids with specific weight under 1,20 g/cm³
- **Sealing system with antiblow out design**
- Ball entirely in talc-filled PP
- Can be maintained with the valve body installed
- Can be **installed** in either a **vertical** (preferable) or **horizontal position**