

VKRBM - DUAL BLOCK® regulating ball valve DN 10:50

DUAL BLOCK® regulating ball valve with long spigot male ends in PP-H for butt welding or electrofusion (CVDm).

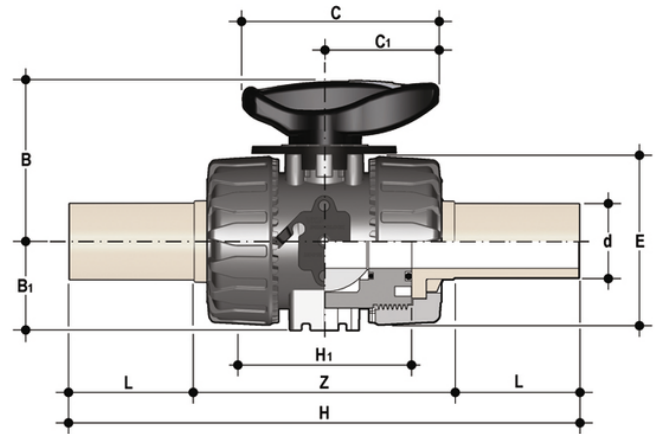

EPDM

Reference	tooltiplmage	system	Category	family	series	d	DN	PN	B	B ₁	C	C[5:1]	E	H	H ₁	L	Z	g
VKRBM020E	-	PP-H system	Manual valves	Ball valves	VKR DN 10÷50	20	15	10	54	29	67	40	54	175	65	40,5	94	220
VKRBM025E	-	PP-H system	Manual valves	Ball valves	VKR DN 10÷50	25	20	10	65	35	85	49	65	212	70	54	106	340
VKRBM032E	-	PP-H system	Manual valves	Ball valves	VKR DN 10÷50	32	25	10	70	39	85	49	73	226	78	56	117	443
VKRBM040E	-	PP-H system	Manual valves	Ball valves	VKR DN 10÷50	40	32	10	83	46	108	64	86	246	88	56	131	593
VKRBM050E	-	PP-H system	Manual valves	Ball valves	VKR DN 10÷50	50	40	10	89	52	108	64	98	271	93	60,5	145	945
VKRBM063E	-	PP-H system	Manual valves	Ball valves	VKR DN 10÷50	63	50	10	108	62	134	76	122	300	111	65,5	161	1607

EPDM

Reference	tooltiplmage	system	Category	family	series	d	DN	PN	B	B ₁	C	C[5:1]	E	H	H ₁	L	Z	g
VKRBM020EOLF	-	PP-H system	Manual valves	Ball valves	VKR DN 10÷50	20	15	10	54	29	67	40	54	175	65	40,5	94	220
VKRBM025EOLF	-	PP-H system	Manual valves	Ball valves	VKR DN 10÷50	25	20	10	65	35	85	49	65	212	70	54	106	340

VKRBM - DUAL BLOCK®

regulating ball valve DN 10:50

Reference	tooltiplmage	system	Category	family	series	d	DN	PN	B	B ₁	C	C[5:1]	E	H	H ₁	L	Z	g
VKRBM032EOLF	-	PP-H system	Manual valves	Ball valves	VKR DN 10÷50	32	25	10	70	39	85	49	73	226	78	56	117	443
VKRBM040EOLF	-	PP-H system	Manual valves	Ball valves	VKR DN 10÷50	40	32	10	83	46	108	64	86	246	88	56	131	593
VKRBM050EOLF	-	PP-H system	Manual valves	Ball valves	VKR DN 10÷50	50	40	10	89	52	108	64	98	271	93	60,5	145	945
VKRBM063EOLF	-	PP-H system	Manual valves	Ball valves	VKR DN 10÷50	63	50	10	108	62	134	76	122	300	111	65,5	161	1607

EPDM

Reference	tooltiplmage	system	Category	family	series	d	DN	PN	B	B ₁	C	C[5:1]	E	H	H ₁	L	Z	g
VKRBM020E0SF	-	PP-H system	Manual valves	Ball valves	VKR DN 10÷50	20	15	10	54	29	67	40	54	175	65	40,5	94	220
VKRBM025E0SF	-	PP-H system	Manual valves	Ball valves	VKR DN 10÷50	25	20	10	65	35	85	49	65	212	70	54	106	340
VKRBM032E0SF	-	PP-H system	Manual valves	Ball valves	VKR DN 10÷50	32	25	10	70	39	85	49	73	226	78	56	117	443
VKRBM040E0SF	-	PP-H system	Manual valves	Ball valves	VKR DN 10÷50	40	32	10	83	46	108	64	86	246	88	56	131	593
VKRBM050E0SF	-	PP-H system	Manual valves	Ball valves	VKR DN 10÷50	50	40	10	89	52	108	64	98	271	93	60,5	145	945
VKRBM063E0SF	-	PP-H system	Manual valves	Ball valves	VKR DN 10÷50	63	50	10	108	62	134	76	122	300	111	65,5	161	1607

FKM

Reference	tooltiplmage	system	Category	family	series	d	DN	PN	B	B ₁	C	C[5:1]	E	H	H ₁	L	Z	g
VKRBM020F	-	PP-H system	Manual valves	Ball valves	VKR DN 10÷50	20	15	10	54	29	67	40	54	175	65	40,5	94	220
VKRBM025F	-	PP-H system	Manual valves	Ball valves	VKR DN 10÷50	25	20	10	65	35	85	49	65	212	70	54	106	340
VKRBM032F	-	PP-H system	Manual valves	Ball valves	VKR DN 10÷50	32	25	10	70	39	85	49	73	226	78	56	117	443
VKRBM040F	-	PP-H system	Manual valves	Ball valves	VKR DN 10÷50	40	32	10	83	46	108	64	86	246	88	56	131	593
VKRBM050F	-	PP-H system	Manual valves	Ball valves	VKR DN 10÷50	50	40	10	89	52	108	64	98	271	93	60,5	145	945
VKRBM063F	-	PP-H system	Manual valves	Ball valves	VKR DN 10÷50	63	50	10	108	62	134	76	122	300	111	65,5	161	1607

FKM

VKRBM - DUAL BLOCK® regulating ball valve DN 10:50

Reference	tooltiplmage	system	Category	family	series	d	DN	PN	B	B ₁	C	C[5:1]	E	H	H ₁	L	Z	g
VKRBM020FOLF	-	PP-H system	Manual valves	Ball valves	VKR DN 10÷50	20	15	10	54	29	67	40	54	175	65	40,5	94	220
VKRBM025FOLF	-	PP-H system	Manual valves	Ball valves	VKR DN 10÷50	25	20	10	65	35	85	49	65	212	70	54	106	340
VKRBM032FOLF	-	PP-H system	Manual valves	Ball valves	VKR DN 10÷50	32	25	10	70	39	85	49	73	226	78	56	117	443
VKRBM040FOLF	-	PP-H system	Manual valves	Ball valves	VKR DN 10÷50	40	32	10	83	46	108	64	86	246	88	56	131	593
VKRBM050FOLF	-	PP-H system	Manual valves	Ball valves	VKR DN 10÷50	50	40	10	89	52	108	64	98	271	93	60,5	145	945
VKRBM063FOLF	-	PP-H system	Manual valves	Ball valves	VKR DN 10÷50	63	50	10	108	62	134	76	122	300	111	65,5	161	1607

FKM

Reference	tooltiplmage	system	Category	family	series	d	DN	PN	B	B ₁	C	C[5:1]	E	H	H ₁	L	Z	g
VKRBM020FOSF	-	PP-H system	Manual valves	Ball valves	VKR DN 10÷50	20	15	10	54	29	67	40	54	175	65	40,5	94	220
VKRBM025FOSF	-	PP-H system	Manual valves	Ball valves	VKR DN 10÷50	25	20	10	65	35	85	49	65	212	70	54	106	340
VKRBM032FOSF	-	PP-H system	Manual valves	Ball valves	VKR DN 10÷50	32	25	10	70	39	85	49	73	226	78	56	117	443
VKRBM040FOSF	-	PP-H system	Manual valves	Ball valves	VKR DN 10÷50	40	32	10	83	46	108	64	86	246	88	56	131	593
VKRBM050FOSF	-	PP-H system	Manual valves	Ball valves	VKR DN 10÷50	50	40	10	89	52	108	64	98	271	93	60,5	145	945
VKRBM063FOSF	-	PP-H system	Manual valves	Ball valves	VKR DN 10÷50	63	50	10	108	62	134	76	122	300	111	65,5	161	1607

VKRBM – DUAL BLOCK®

regulating ball valve DN 10:50

- HIPVC ergonomic multifunctional handle with **position indicator** and tool to adjust the ball seat carrier
- Flow direction and opening angle indication plate with **graduated scale with 5° detail** for clear and accurate readings
- 90° operating angle that permits **the use of standard** quarter turn **actuators**
- The patented ball design provides **linear flow adjustment** throughout its range of operation even when the valve is open just a few degrees and guarantees minimum pressure drops
- Patented **DUAL BLOCK®** system: prevents union nuts from loosening even under extreme operating conditions: e.g. vibration or thermal expansion

- Connection system for solvent weld, threaded and flanged joints
- Patented **SEAT STOP®** ball carrier system that lets you micro-adjust seals and minimise the axial force effect
- Easy radial dismounting allowing quick replacement of O-rings and ball seats without any need for tools
- **PN16 True Union valve body** made for rigid PVC-U injection moulding equipped with built-in bores for actuation. ISO 9393 compliant test requisites
- Option of dismounting downstream pipes with the valve in the closed position
- High surface finish stem with double O-Ring and double connection key to ball
- **Integrated bracket** for valve anchoring
- Ball seat carrier can be adjusted using the **Easytorque adjustment kit**
- Actuation option: version with electric modulating actuator with 4-20 mA / 0-10 V inlet and 4-20 mA / 0-10 V outlet to monitor the position
- Valve suitable for carrying fluids that are clean and free of suspended particles