

VKDOF - DUAL BLOCK® 2-way ball valve DN 10:50

DUAL BLOCK® 2-way ball valve with fixed flanges, drilled EN/ISO/DIN PN10/16. Face to face according to EN 558-1.

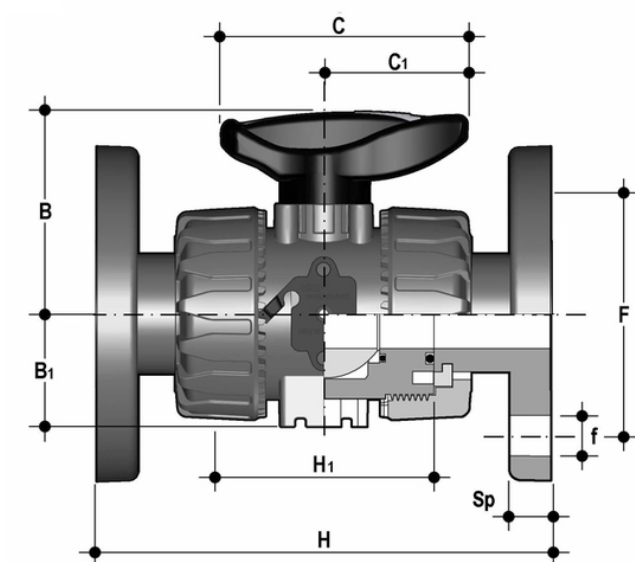

Reference	tooltiplmage	system	Category	family	series	d	DN	PN	B	B ₁	C	C[5:1]	F	f	H	H ₁	Sp	U	g
VKDOF020F	-	PVDF system	Manual valves	Ball valves	VKD DN 10÷50	20	15	16	54	29	67	40	65	14	130	65	11	4	547
VKDOF025F	-	PVDF system	Manual valves	Ball valves	VKD DN 10÷50	25	20	16	65	34,5	85	49	75	14	150	70	14	4	772
VKDOF032F	-	PVDF system	Manual valves	Ball valves	VKD DN 10÷50	32	25	16	69,5	39	85	49	85	14	160	78	14	4	1024
VKDOF040F	-	PVDF system	Manual valves	Ball valves	VKD DN 10÷50	40	32	16	82,5	46	108	64	100	18	180	88	14	4	1583
VKDOF050F	-	PVDF system	Manual valves	Ball valves	VKD DN 10÷50	50	40	16	89	52	108	64	110	18	200	93	16	4	2024
VKDOF063F	-	PVDF system	Manual valves	Ball valves	VKD DN 10÷50	63	50	16	108	62	134	76	125	18	230	111	16	4	3219

VKDOF – DUAL BLOCK® 2-way ball valve DN 10:50

- Ergonomic HIPVC handle equipped with **removable tool to adjust the ball seat carrier**
- **Handle lock 0°– 90°** SHKD (available as an accessory) ergonomically operable during service and padlockable
- Robust **integrated bracket for valve anchoring**, for easy and quick automation even after valve installation on the system via the Power Quick module (optional)
- **DUAL BLOCK®** patented lock system that ensures union nut tightening hold even in severe conditions such as vibrations or heat dilation
- Machined high surface finish ball that guarantees a smooth operation and increased reliability

- Connection system for solvent weld, threaded and flanged joints
- Patented **SEAT STOP®** ball carrier system that lets you micro-adjust ball seats and minimise the axial force effect
- Easy radial dismounting allowing quick replacement of O-rings and ball seats without any need for tools
- **PN16 True Union valve body** made for rigid PVC-U injection moulding equipped with built-in bores for actuation. ISO 9393 compliant test requisites
- Option of dismounting downstream pipes with the valve in the closed position
- Floating **full bore ball** with high surface finish
- **Integrated bracket** for valve anchoring
- Ball seat carriers can be adjusted using the **Easytorque adjustment kit**
- Possibility to have handle with integrated LSQT limit micro switch, even as a retrofit in existing installations