

LKDFM - DUAL BLOCK® 3-way ball valve DN 15:50

DUAL BLOCK® 3-way ball valve with BS parallel socket threaded ends, L bore.

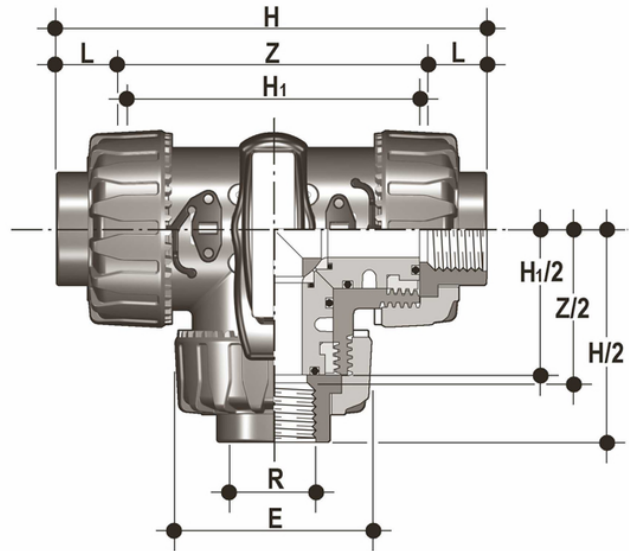

EPDM

Reference	tooltiplmage	system	Category	family	series	R	DN	PN	E	H	H ₁	L	Z	g
LKDFM012E	-	PP-H system	Manual valves	Ball valves	TKD DN 10÷50	1/2"	15	10	54	117	80	15	87	195
LKDFM034E	-	PP-H system	Manual valves	Ball valves	TKD DN 10÷50	3/4"	20	10	65	143	100	16	114	350
LKDFM100E	-	PP-H system	Manual valves	Ball valves	TKD DN 10÷50	1"	25	10	73	157	110	19	120	505
LKDFM114E	-	PP-H system	Manual valves	Ball valves	TKD DN 10÷50	1" 1/4	32	10	86	185	131	21	140	820
LKDFM112E	-	PP-H system	Manual valves	Ball valves	TKD DN 10÷50	1" 1/2	40	10	98	217	148	21	172	1070
LKDFM200E	-	PP-H system	Manual valves	Ball valves	TKD DN 10÷50	2"	50	10	122	266	179	26	211	1795

FKM

Reference	tooltiplmage	system	Category	family	series	R	DN	PN	E	H	H ₁	L	Z	g
LKDFM012F	-	PP-H system	Manual valves	Ball valves	TKD DN 10÷50	1/2"	15	10	54	117	80	15	87	195
LKDFM034F	-	PP-H system	Manual valves	Ball valves	TKD DN 10÷50	3/4"	20	10	65	143	100	16	114	350
LKDFM100F	-	PP-H system	Manual valves	Ball valves	TKD DN 10÷50	1"	25	10	73	157	110	19	120	505
LKDFM114F	-	PP-H system	Manual valves	Ball valves	TKD DN 10÷50	1" 1/4	32	10	86	185	131	21	140	820
LKDFM112F	-	PP-H system	Manual valves	Ball valves	TKD DN 10÷50	1" 1/2	40	10	98	217	148	21	172	1070
LKDFM200F	-	PP-H system	Manual valves	Ball valves	TKD DN 10÷50	2"	50	10	122	266	179	26	211	1795

LKDFM – DUAL BLOCK® 3-way ball valve DN 15:50

- Ergonomic HIPVC handle equipped with removable tool to adjust the ball seat carrier. Possibility of installing the **LTKD stroke limiter** (available as an accessory) that permits ball and handle rotation only for set opening and closing angles at 90° or 180°
- **Handle lock 0°– 90° SHKD** (available as an accessory) ergonomically operable during service and padlockable
- **DUAL BLOCK®** patented lock system that ensures union nut tightening hold even in severe conditions such as vibrations or heat dilation
- **Ball shutter** high surface finish with floating type full passage with **T or L port**
- **4 PTFE ball seat system** that compensates axial force guaranteeing optimal manageability and long working life

- Connection system for weld and threaded joints
- Patented **SEAT STOP®** ball seat carrier system that lets you micro-adjust ball seats and minimise axial force effects
- Easy radial disassembly allowing quick replacement of O-rings and ball seats without any need for tools
- PN10 **True Union valve body** made for PP-H injection moulding equipped with built-in bores for actuation. ISO 9393 compliant test requisites
- Option of disassembling downstream pipes with the valve in the closed position
- High surface finish stem with double O-Ring and double groove ball connection, equipped with **optical position indicator** for correct handle installation
- **Integrated bracket** for valve anchoring
- Possibility of installing pneumatic and/or electric actuators thanks to the robust integrated bracket for valve anchoring for easy and quick automation using the Power Quick module (optional)
- Possibility to have handle with integrated LSQT limit micro switch, even as a retrofit in existing installations