

# VKROAF – DUAL BLOCK® regulating ball valve DN 10:50

DUAL BLOCK® regulating ball valve with ANSI B16.5 cl.150#FF fixed flange bore.

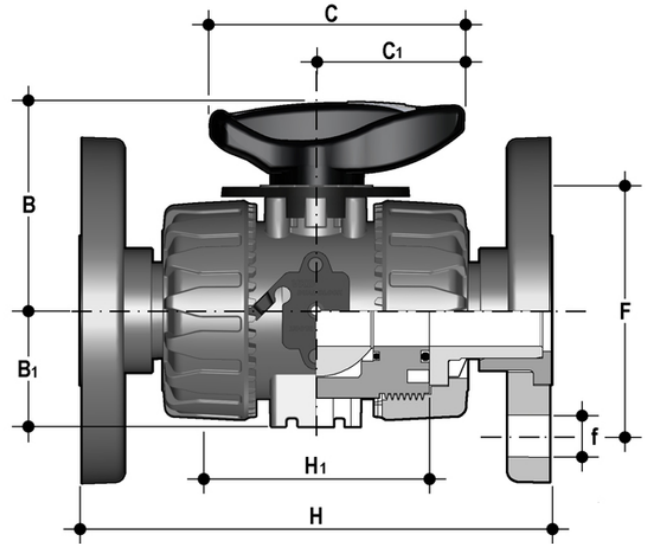

Reference	system	Category	family	series	d	DN	PN	B	B <sub>1</sub>	C	C <sub>1</sub>	F	f	H	H <sub>1</sub>	Sp	U	g
VKROAF012F	PVDF system	Manual valves	Ball valves	VKR DN 10÷50	1/2"	15	16	54	29	67	40	60,3	15,9	143	65	11	4	547
VKROAF034F	PVDF system	Manual valves	Ball valves	VKR DN 10÷50	3/4"	20	16	65	34,5	85	49	69,9	15,9	172	70	14	4	772
VKROAF100F	PVDF system	Manual valves	Ball valves	VKR DN 10÷50	1"	25	16	69,5	39	85	49	79,4	15,9	187	78	14	4	1024
VKROAF112F	PVDF system	Manual valves	Ball valves	VKR DN 10÷50	1" 1/2	40	16	89	52	108	64	98,4	15,9	212	93	16	4	2024
VKROAF114F	PVDF system	Manual valves	Ball valves	VKR DN 10÷50	1" 1/4	32	16	82,5	46	108	64	88,9	15,9	190	88	14	4	1583
VKROAF200F	PVDF system	Manual valves	Ball valves	VKR DN 10÷50	2"	50	16	108	62	134	76	120,7	19,1	234	111	16	4	3219

# VKROAF – DUAL BLOCK®

## regulating ball valve DN 10:50

- HIPVC ergonomic multifunctional handle with **position indicator** and tool to adjust the ball seat carrier
- Flow direction and opening angle indication plate with **graduated scale with 5° detail** for clear and accurate readings
- 90° operating angle that permits **the use of standard** quarter turn **actuators**
- The patented ball design provides **linear flow adjustment** throughout its range of operation even when the valve is open just a few degrees and guarantees minimum pressure drops
- Patented **DUAL BLOCK®** system: prevents union nuts from loosening even under extreme operating conditions: e.g. vibration or thermal expansion
  
- Connection system for solvent weld, threaded and flanged joints
- Patented **SEAT STOP®** ball carrier system that lets you micro-adjust seals and minimise the axial force effect
- Easy radial dismounting allowing quick replacement of O-rings and ball seats without any need for tools
- **PN16 True Union valve body** made for rigid PVC-U injection moulding equipped with built-in bores for actuation. ISO 9393 compliant test requisites
- Option of dismounting downstream pipes with the valve in the closed position
- High surface finish stem with double O-Ring and double connection key to ball
- **Integrated bracket** for valve anchoring
- Ball seat carrier can be adjusted using the **Easytorque adjustment kit**
- Actuation option: version with electric modulating actuator with 4-20 mA / 0-10 V inlet and 4-20 mA / 0-10 V outlet to monitor the position
- Valve suitable for carrying fluids that are clean and free of suspended particles