

VXEBEV - Easyfit 2-way ball valve DN 10:50

Easyfit 2-way ball valve with PE100 SDR 11 male end connectors for butt welding or electrofusion (CVDE).

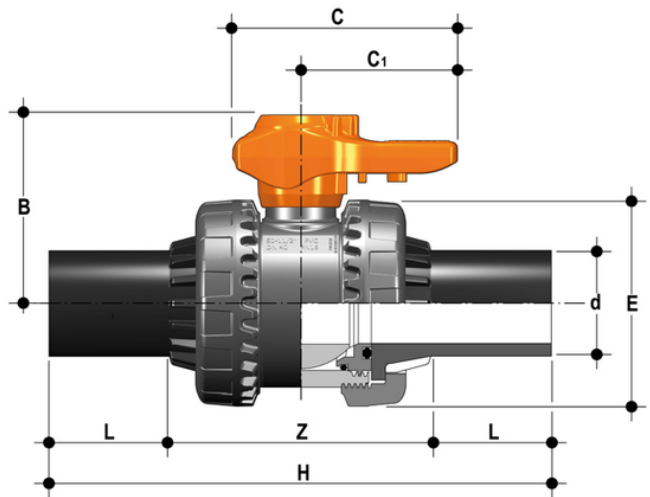

EPDM

Reference	tooltiplmage	system	Category	family	series	d	DN	PN	B	C	C[5:1]	E	H	L	Z	g
VXEBEV020E	-	PVC-U system	Manual valves	Ball valves	VXE DN 10÷50	20	15	16	49	64	44	54	154	40,5	73	180
VXEBEV025E	-	PVC-U system	Manual valves	Ball valves	VXE DN 10÷50	25	20	16	62	78	55	63	189	54	81	269
VXEBEV032E	-	PVC-U system	Manual valves	Ball valves	VXE DN 10÷50	32	25	16	71	87	60	72	203	56	91	379
VXEBEV040E	-	PVC-U system	Manual valves	Ball valves	VXE DN 10÷50	40	32	16	82	102	72	85	221	56	109	591
VXEBEV050E	-	PVC-U system	Manual valves	Ball valves	VXE DN 10÷50	50	40	16	92	109	76	100	246	60,5	125	851
VXEBEV063E	-	PVC-U system	Manual valves	Ball valves	VXE DN 10÷50	63	50	16	110	133	94	118	276	65,5	145	1407

FKM

Reference	tooltiplmage	system	Category	family	series	d	DN	PN	B	C	C[5:1]	E	H	L	Z	g
VXEBEV020F	-	PVC-U system	Manual valves	Ball valves	VXE DN 10÷50	20	15	16	49	64	44	54	154	40,5	73	180
VXEBEV025F	-	PVC-U system	Manual valves	Ball valves	VXE DN 10÷50	25	20	16	62	78	55	63	189	54	81	269



VXEBEV – Easyfit 2-way ball valve DN 10:50

Reference	tooltiplmage	system	Category	family	series	d	DN	PN	B	C	C[5:1]	E	H	L	Z	g
VXEBEV032F	-	PVC-U system	Manual valves	Ball valves	VXE DN 10÷50	32	25	16	71	87	60	72	203	56	91	379
VXEBEV040F	-	PVC-U system	Manual valves	Ball valves	VXE DN 10÷50	40	32	16	82	102	72	85	221	56	109	591
VXEBEV050F	-	PVC-U system	Manual valves	Ball valves	VXE DN 10÷50	50	40	16	92	109	76	100	246	60,5	125	851
VXEBEV063F	-	PVC-U system	Manual valves	Ball valves	VXE DN 10÷50	63	50	16	110	133	94	118	276	65,5	145	1407

VXEBEV – Easyfit 2-way ball valve

DN 10:50

- Two position **Easyfit ergonomic multifunctional handle with union nut tightening control** which can be used to **adjust ball seat carriers**. Handle use is especially indicated for **maintenance** work where **space is limited** and hard to access
- **Customisable Labelling System: built-in LCE module** on the handle made up of a transparent protection plug and customisable tag holder with LSE set (available as accessory). The customisation potential lets you **identify the valve on the system** according to specific needs
- **The PTFE ball seat system with locked carrier** adjustable via Easyfit multifunctional handle or Easytorque adjustment kit (available as an accessory)
- High surface finish **valve stem with double O-Ring**, produced in CNC work stations to achieve precise dimensional tolerance and increased reliability
- Machined high surface finish ball that guarantees a smooth operation and increased reliability
- **Patented Easyfit system**: innovative mechanism based on the principle of the bevel gear pair that controls valve union nut rotation during installation
- Connection system for solvent weld and threaded joints
- **Valve material compatibility** (PVC-C) and elastomer **seal elements** (EPDM or FKM), with water, drinking water and other food substances as per **current regulations**
- Easy radial disassembly allowing quick replacement of O-rings and ball seats without any need for tools
- **PN16 True Union valve body** made for PVC-C injection moulding and European Directive 2014/68/EU (PED) compliant for pressurised equipment. ISO 9393 compliant test requirements
- Fully interchangeable with previous VX Ergo series models
- Option of disassembling downstream pipes with the valve in the closed position
- Floating **full bore ball** with high surface finish made in CNC work stations to achieve precise dimensional tolerance and high surface finish