

# VKRDV - DUAL BLOCK® regulating ball valve DN 10:50

DUAL BLOCK® regulating ball valve with male ends for solvent welding, metric series.

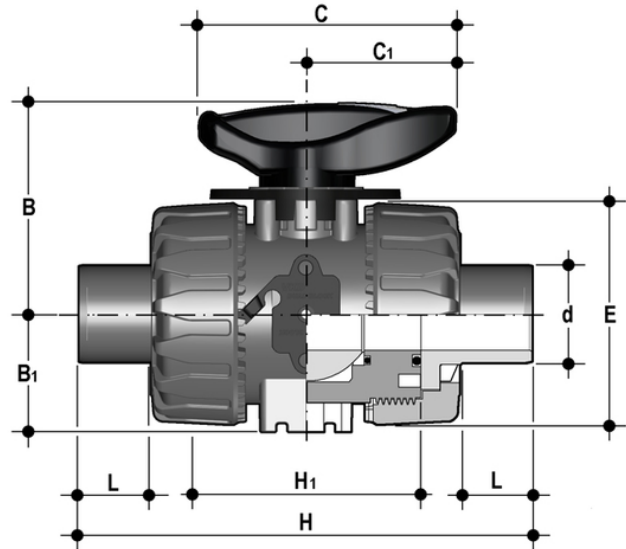

## EPDM

Reference	system	Category	family	series	d	DN	PN	B	B <sub>1</sub>	C	C <sub>1</sub>	E	H	H <sub>1</sub>	L	g
VKRDV016E	PVC-U system	Manual valves	Ball valves	VKR DN 10÷50	16	10	16	54	29	67	40	54	149	65	14	215
VKRDV020E	PVC-U system	Manual valves	Ball valves	VKR DN 10÷50	20	15	16	54	29	67	40	54	124	65	16	220
VKRDV025E	PVC-U system	Manual valves	Ball valves	VKR DN 10÷50	25	20	16	65	34,5	85	49	65	144	70	19	340
VKRDV032E	PVC-U system	Manual valves	Ball valves	VKR DN 10÷50	32	25	16	69,5	39	85	49	73	154	78	22	443
VKRDV040E	PVC-U system	Manual valves	Ball valves	VKR DN 10÷50	40	32	16	82,5	46	108	64	86	174	88	26	693
VKRDV050E	PVC-U system	Manual valves	Ball valves	VKR DN 10÷50	50	40	16	89	52	108	64	98	194	93	31	945
VKRDV063E	PVC-U system	Manual valves	Ball valves	VKR DN 10÷50	63	50	16	108	62	134	76	122	224	111	38	1607

## FKM

Reference	system	Category	family	series	d	DN	PN	B	B <sub>1</sub>	C	C <sub>1</sub>	E	H	H <sub>1</sub>	L	g
VKRDV016F	PVC-U system	Manual valves	Ball valves	VKR DN 10÷50	16	10	16	54	29	67	40	54	149	65	14	215
VKRDV020F	PVC-U system	Manual valves	Ball valves	VKR DN 10÷50	20	15	16	54	29	67	40	54	124	65	16	220
VKRDV025F	PVC-U system	Manual valves	Ball valves	VKR DN 10÷50	25	20	16	65	34,5	85	49	65	144	70	19	340
VKRDV032F	PVC-U system	Manual valves	Ball valves	VKR DN 10÷50	32	25	16	69,5	39	85	49	73	154	78	22	443
VKRDV040F	PVC-U system	Manual valves	Ball valves	VKR DN 10÷50	40	32	16	82,5	46	108	64	86	174	88	26	693
VKRDV050F	PVC-U system	Manual valves	Ball valves	VKR DN 10÷50	50	40	16	89	52	108	64	98	194	93	31	945
VKRDV063F	PVC-U system	Manual valves	Ball valves	VKR DN 10÷50	63	50	16	108	62	134	76	122	224	111	38	1607

# VKRDV – DUAL BLOCK® regulating ball valve DN 10:50

- HIPVC ergonomic multifunctional handle with **position indicator** and tool to adjust the ball seat carrier
- Flow direction and opening angle indication plate with **graduated scale with 5° detail** for clear and accurate readings
- 90° operating angle that permits **the use of standard** quarter turn **actuators**
- The patented ball design provides **linear flow adjustment** throughout its range of operation even when the valve is open just a few degrees and guarantees minimum pressure drops
- Patented **DUAL BLOCK®** system: prevents union nuts from loosening even under extreme operating conditions: e.g. vibration or thermal expansion
  
- Connection system for solvent weld, threaded and flanged joints
- Patented **SEAT STOP®** ball carrier system that lets you micro-adjust seals and minimise the axial force effect
- Easy radial dismounting allowing quick replacement of O-rings and ball seats without any need for tools
- **PN16 True Union valve body** made for rigid PVC-U injection moulding equipped with built-in bores for actuation. ISO 9393 compliant test requisites
- Option of dismounting downstream pipes with the valve in the closed position
- High surface finish stem with double O-Ring and double connection key to ball
- **Integrated bracket** for valve anchoring
- Ball seat carrier can be adjusted using the **Easytorque adjustment kit**
- Actuation option: version with electric modulating actuator with 4-20 mA / 0-10 V inlet and 4-20 mA / 0-10 V outlet to monitor the position
- Valve suitable for carrying fluids that are clean and free of suspended particles