

VKDJV - DUAL BLOCK® 2-way ball valve DN 10:50

DUAL BLOCK® 2-way ball valve with female ends for solvent welding, JIS series.

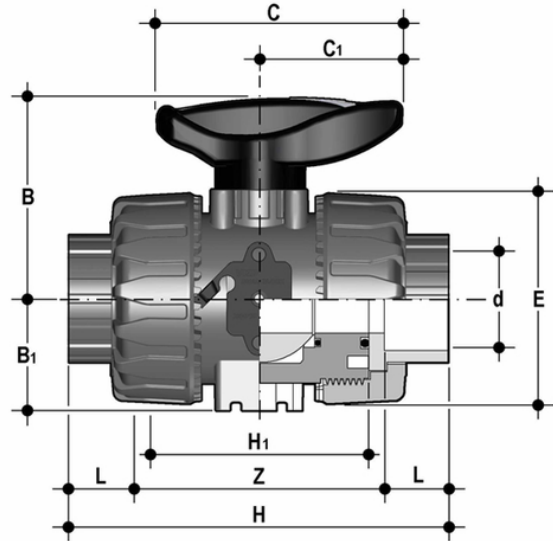

EPDM

Reference	tooltiplmage	system	Category	family	series	d	DN	PN	B	B ₁	C	C[5:1]	E	H	H ₁	L	Z	g
VKDJV012E	-	PVC-U system	Manual valves	Ball valves	VKD DN 10÷50	1/2"	15	16	54	29	67	40	54	131	65	30	71	225
VKDJV034E	-	PVC-U system	Manual valves	Ball valves	VKD DN 10÷50	3/4"	20	16	65	34,5	85	49	65	147	70	35	77	335
VKDJV100E	-	PVC-U system	Manual valves	Ball valves	VKD DN 10÷50	1"	25	16	69,5	39	85	49	73	164	78	40	84	448
VKDJV114E	-	PVC-U system	Manual valves	Ball valves	VKD DN 10÷50	1" 1/4	32	16	82,5	46	108	64	86	182	88	44	94	728
VKDJV112E	-	PVC-U system	Manual valves	Ball valves	VKD DN 10÷50	1" 1/2	40	16	89	52	108	64	98	212	93	55	102	1015
VKDJV200E	-	PVC-U system	Manual valves	Ball valves	VKD DN 10÷50	2"	50	16	108	62	134	76	122	248	111	63	122	1727

FKM

Reference	tooltiplmage	system	Category	family	series	d	DN	PN	B	B ₁	C	C[5:1]	E	H	H ₁	L	Z	g
VKDJV012F	-	PVC-U system	Manual valves	Ball valves	VKD DN 10÷50	1/2"	15	16	54	29	67	40	54	131	65	30	71	225
VKDJV034F	-	PVC-U system	Manual valves	Ball valves	VKD DN 10÷50	3/4"	20	16	65	34,5	85	49	65	147	70	35	77	335

VKDJV - DUAL BLOCK® 2-way ball valve DN 10:50

Reference	tooltiplmage	system	Category	family	series	d	DN	PN	B	B ₁	C	C[5:1]	E	H	H ₁	L	Z	g
VKDJV100F	-	PVC-U system	Manual valves	Ball valves	VKD DN 10÷50	1"	25	16	69,5	39	85	49	73	164	78	40	84	448
VKDJV114F	-	PVC-U system	Manual valves	Ball valves	VKD DN 10÷50	1" 1/4	32	16	82,5	46	108	64	86	182	88	44	94	728
VKDJV112F	-	PVC-U system	Manual valves	Ball valves	VKD DN 10÷50	1" 1/2	40	16	89	52	108	64	98	212	93	55	102	1015
VKDJV200F	-	PVC-U system	Manual valves	Ball valves	VKD DN 10÷50	2"	50	16	108	62	134	76	122	248	111	63	122	1727

VKDJV – DUAL BLOCK® 2-way ball valve DN 10:50

- Ergonomic HIPVC handle equipped with **removable tool to adjust the ball seat carrier**.
- **Handle lock 0°– 90° SHKD** (available as an accessory) ergonomically operable during service and padlockable
- Robust **integrated bracket for valve anchoring**, for easy and quick automation even after valve installation on the system via the Power Quick module (optional)
- **DUAL BLOCK®** patented lock system that ensures union nut tightening hold even in severe conditions such as vibrations or heat dilation
- Machined high surface finish ball that guarantees a smooth operation and increased reliability

- Connection system for solvent weld, threaded and flanged joints
- Patented **SEAT STOP®** ball carrier system that lets you micro-adjust ball seats and minimise the axial force effect
- Easy radial dismounting allowing quick replacement of O-rings and ball seats without any need for tools
- **PN16 True Union valve body** made for rigid PVC-U injection moulding equipped with built-in bores for actuation. ISO 9393 compliant test requisites
- Option of dismounting downstream pipes with the valve in the closed position
- Floating **full bore ball** with high surface finish
- **Integrated bracket** for valve anchoring
- Ball seat carriers can be adjusted using the **Easytorque adjustment kit**
- Possibility to have handle with integrated LSQT limit micro switch, even as a retrofit in existing installations