

VVDV - Angle seat valve DN 10:50

Angle seat valve with male ends for solvent welding, metric series.

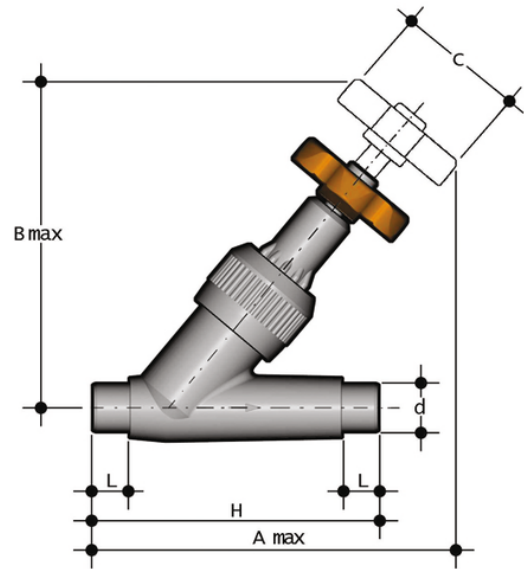

| Reference | tooltiplmage | system | Category | family | series | d | DN | PN | A max | B max | C | H | L | g |
|-----------|--------------|--------------|---------------|------------------|-------------|----|----|----|-------|-------|-----|-----|----|------|
| VVDV016E | - | PVC-U system | Manual valves | Auxiliary valves | VV DN 10+50 | 16 | 10 | 16 | 136 | 124 | 60 | 114 | 14 | 150 |
| VVDV020E | - | PVC-U system | Manual valves | Auxiliary valves | VV DN 10+50 | 20 | 15 | 16 | 146 | 124 | 60 | 124 | 16 | 160 |
| VVDV025E | - | PVC-U system | Manual valves | Auxiliary valves | VV DN 10+50 | 25 | 20 | 16 | 165 | 146 | 60 | 144 | 19 | 250 |
| VVDV032E | - | PVC-U system | Manual valves | Auxiliary valves | VV DN 10+50 | 32 | 25 | 16 | 188 | 173 | 70 | 154 | 22 | 380 |
| VVDV040E | - | PVC-U system | Manual valves | Auxiliary valves | VV DN 10+50 | 40 | 32 | 10 | 217 | 195 | 85 | 174 | 26 | 480 |
| VVDV050E | - | PVC-U system | Manual valves | Auxiliary valves | VV DN 10+50 | 50 | 40 | 10 | 247 | 222 | 105 | 194 | 31 | 820 |
| VVDV063E | - | PVC-U system | Manual valves | Auxiliary valves | VV DN 10+50 | 63 | 50 | 10 | 299 | 269 | 130 | 224 | 38 | 1345 |



VVDV – Angle seat valve DN 10:50

- Connection system for solvent weld, threaded and flanged joints
- Can be installed in any position
- **No metal parts in contact with the fluid**
- **Valve material compatibility** (PVC-U) with water, drinking water and other food substance conveyance according to **current regulations**
- Can be maintained with the valve body installed