

SXEFV - Easyfit true union ball and spring check valve DN 10:50

Easyfit ball check valve with BSP threaded female ends.

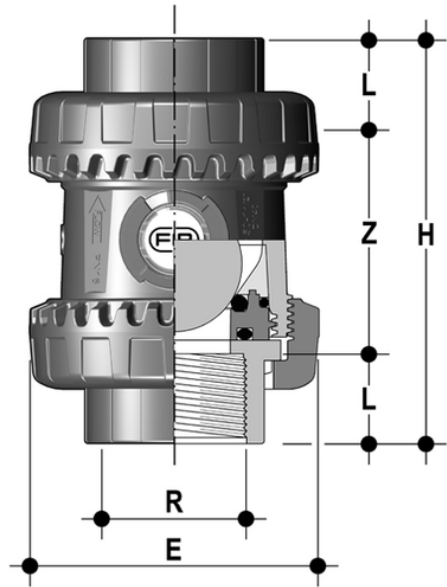

EPDM

Reference	tootiplmage	system	Category	family	series	R	DN	PN	E	H	L	Z	g
SXEFV038E	-	PVC-U system	Manual valves	Auxiliary valves	SXE DN 10÷50	3/8"	10	16	54	82	11,4	59,2	145
SXEFV012E	-	PVC-U system	Manual valves	Auxiliary valves	SXE DN 10÷50	1/2"	15	16	54	90	15	60	148
SXEFV034E	-	PVC-U system	Manual valves	Auxiliary valves	SXE DN 10÷50	3/4"	20	16	63	93	16,3	60,4	190
SXEFV100E	-	PVC-U system	Manual valves	Auxiliary valves	SXE DN 10÷50	1"	25	16	72	110	19,1	71,8	300
SXEFV114E	-	PVC-U system	Manual valves	Auxiliary valves	SXE DN 10÷50	1" 1/4	32	16	85	127	21,4	84,2	460
SXEFV112E	-	PVC-U system	Manual valves	Auxiliary valves	SXE DN 10÷50	1" 1/2	40	16	100	131	21,4	88,2	675
SXEFV200E	-	PVC-U system	Manual valves	Auxiliary valves	SXE DN 10÷50	2"	50	16	118	161	25,7	109,6	1080

FKM

Reference	tootiplmage	system	Category	family	series	R	DN	PN	E	H	L	Z	g
SXEFV038F	-	PVC-U system	Manual valves	Auxiliary valves	SXE DN 10÷50	3/8"	10	16	54	82	11,4	59,2	145
SXEFV012F	-	PVC-U system	Manual valves	Auxiliary valves	SXE DN 10÷50	1/2"	15	16	54	90	15	60	148
SXEFV034F	-	PVC-U system	Manual valves	Auxiliary valves	SXE DN 10÷50	3/4"	20	16	63	93	16,3	60,4	190
SXEFV100F	-	PVC-U system	Manual valves	Auxiliary valves	SXE DN 10÷50	1"	25	16	72	110	19,1	71,8	300
SXEFV114F	-	PVC-U system	Manual valves	Auxiliary valves	SXE DN 10÷50	1" 1/4	32	16	85	127	21,4	84,2	460
SXEFV112F	-	PVC-U system	Manual valves	Auxiliary valves	SXE DN 10÷50	1" 1/2	40	16	100	131	21,4	88,2	675
SXEFV200F	-	PVC-U system	Manual valves	Auxiliary valves	SXE DN 10÷50	2"	50	16	118	161	25,7	109,6	1080

SXEFV – Easyfit true union ball and spring check valve DN 10:50

- **Customisable Labelling System: built-in LCE module** on the valve body made up of transparent protection plug and customisable tag holder using the LSE set (available as accessory). The customisation potential lets you identify the valve on the system according to specific needs.
- **Optimised dynamic fluid design:** energy savings thanks to the improved valve Kv value with consequent pressure drop reduction
- High surface finish ball shutter: **wear reduction**, increase in working life and reduced valve maintenance. Ideal for conveying dirty fluids, even with suspended solids and filaments thanks to the special design that permits **internal valve selfcleaning**
- **Locked ball seat carrier:** safe dismounting for maintenance with the Easyfit multifunctional handle or Easytorque kit
- Ideal for horizontal installations: **perfect seal even with low back pressure. Silent** and durable even with strong vibrations and pulsating fluid
- PVC-U shutter and springs available made of STAINLESS steel 316, Hastelloy C276, A316 PTFE encapsulated: maximum reliability in a **wide field of applications** from salt water to aggressive acids
- Connection system for solvent weld and threaded joints
- **Valve material compatibility (PVC-U)** with water conveyance, drinking water and other food substances according to current regulations
- **PN16 True Union** valve body made for PVC-U injection moulding and European Directive 2014/68/EU (PED) compliant for pressurised equipment. ISO 9393 compliant test requirements
- **Short face to face dimension** according to international regulation ISO 7508 series III and European regulation EN 1452 "short" and fully interchangeable with VXE and VEE DN 10÷50 ball valve models
- Union nuts with rack for tightening adjustment via Easyfit handle or via Easytorque adjustment kit (available as accessories)
- **Vertical** (preferable for SXE model) and **horizontal installation** potential