

VZIV – Foot valve DN 10:50

Foot valve with male ends for solvent welding, metric series.

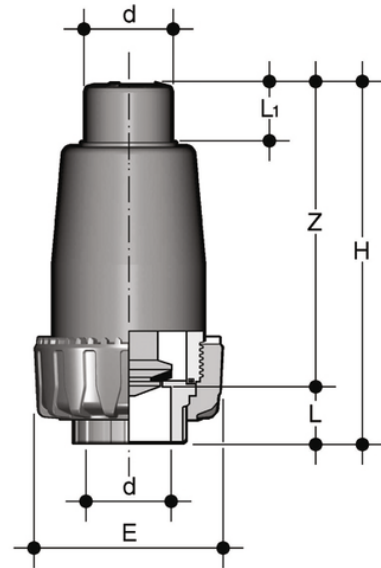

| Reference | system | Category | family | series | d | DN | PN | E | H | L | L ₁ | Z | g |
|-----------|--------------|---------------|------------------|-------------|----|----|----|-----|-----|----|----------------|-----|------|
| VZIV016E | PVC-U system | Manual valves | Auxiliary valves | VZ DN 10÷50 | 16 | 10 | 16 | 55 | 101 | 14 | 15 | 87 | 105 |
| VZIV020E | PVC-U system | Manual valves | Auxiliary valves | VZ DN 10÷50 | 20 | 15 | 16 | 55 | 103 | 16 | 18 | 87 | 120 |
| VZIV025E | PVC-U system | Manual valves | Auxiliary valves | VZ DN 10÷50 | 25 | 20 | 16 | 66 | 125 | 19 | 20 | 106 | 210 |
| VZIV032E | PVC-U system | Manual valves | Auxiliary valves | VZ DN 10÷50 | 32 | 25 | 16 | 75 | 150 | 22 | 24 | 128 | 350 |
| VZIV040E | PVC-U system | Manual valves | Auxiliary valves | VZ DN 10÷50 | 40 | 32 | 16 | 87 | 171 | 26 | 28 | 145 | 560 |
| VZIV050E | PVC-U system | Manual valves | Auxiliary valves | VZ DN 10÷50 | 50 | 40 | 16 | 100 | 187 | 31 | 34 | 156 | 760 |
| VZIV063E | PVC-U system | Manual valves | Auxiliary valves | VZ DN 10÷50 | 63 | 50 | 16 | 122 | 223 | 38 | 41 | 185 | 1340 |



VZIV – Foot valve DN 10:50

- Connection system for solvent weld and threaded joints
- **No metal parts in contact with the fluid**
- **Piston with incorporated counterweight** able to work with high intensity fluid
- Limited pressure loss. Only minimum back pressure is required for the hermetic seal
- **Valve material compatibility** (PVC-U) with water, drinking water and other food substance conveyance according to **current regulations**
- Can be maintained with the valve body installed