

VVUIV - Angle seat valve DN 10:50

Angle seat valve with female union ends for solvent welding, metric series.

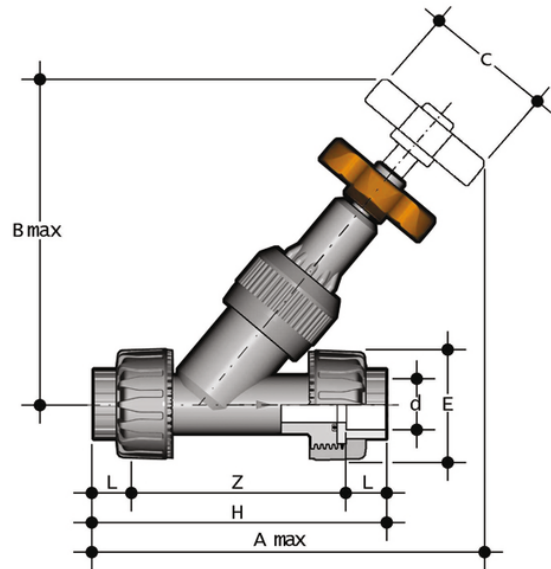

Reference	tooltiplmage	system	Category	family	series	d	DN	PN	A max	B max	C	E	H	L	Z	g
VVUIV016E	-	PVC-U system	Manual valves	Auxiliary valves	VV DN 10÷50	16	10	16	170	124	60	55	135	14	107	238
VVUIV020E	-	PVC-U system	Manual valves	Auxiliary valves	VV DN 10÷50	20	15	16	173	124	60	55	135	16	103	251
VVUIV025E	-	PVC-U system	Manual valves	Auxiliary valves	VV DN 10÷50	25	20	16	197	146	60	66	158	19	120	413
VVUIV032E	-	PVC-U system	Manual valves	Auxiliary valves	VV DN 10÷50	32	25	16	223	173	70	75	176	22	132	621
VVUIV040E	-	PVC-U system	Manual valves	Auxiliary valves	VV DN 10÷50	40	32	16	258	195	85	87	207	26	155	903
VVUIV050E	-	PVC-U system	Manual valves	Auxiliary valves	VV DN 10÷50	50	40	16	295	222	105	100	243	31	181	1320
VVUIV063E	-	PVC-U system	Manual valves	Auxiliary valves	VV DN 10÷50	63	50	16	359	269	130	120	298	38	222	2238



VVUIV - Angle seat valve DN 10:50

- Connection system for solvent weld, threaded and flanged joints
- Can be installed in any position
- **No metal parts in contact with the fluid**
- **Valve material compatibility** (PVC-U) with water, drinking water and other food substance conveyance according to **current regulations**
- Can be maintained with the valve body installed