

# VRIV - Check valve DN 10:100

Check valve with female ends for solvent welding, metric series.

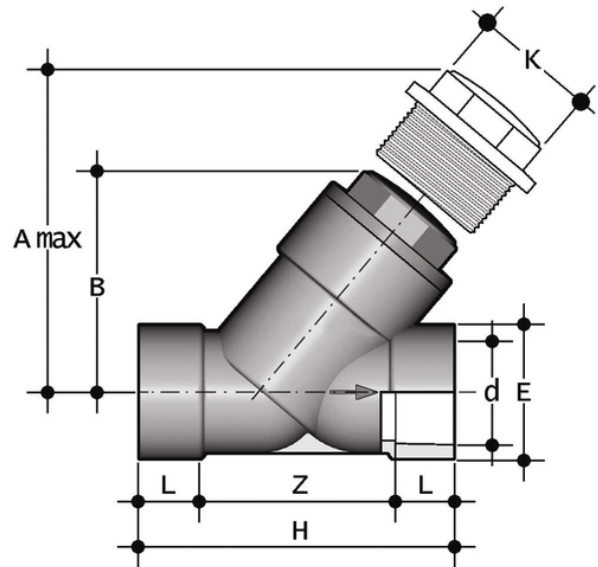

| Reference | tooltiplmage | system       | Category      | family           | series       | d   | DN  | PN | A <sub>max</sub> | B   | E   | H   | K   | L  | Z   | Fig. | g    |
|-----------|--------------|--------------|---------------|------------------|--------------|-----|-----|----|------------------|-----|-----|-----|-----|----|-----|------|------|
| VRIV075E  | -            | PVC-U system | Manual valves | Auxiliary valves | VR DN 10÷100 | 75  | 65  | 10 | 300              | 179 | 104 | 243 | 96  | 44 | 155 | B    | 3485 |
| VRIV090E  | -            | PVC-U system | Manual valves | Auxiliary valves | VR DN 10÷100 | 90  | 80  | 6  | 325              | 192 | 116 | 262 | 105 | 51 | 160 | B    | 4530 |
| VRIV110E  | -            | PVC-U system | Manual valves | Auxiliary valves | VR DN 10÷100 | 110 | 100 | 6  | 385              | 231 | 138 | 325 | -   | 61 | 203 | C    | 7170 |



## VRIV – Check valve DN 10:100

- Connection system for solvent weld, threaded and flanged joints
- **No metal parts in contact with the fluid**
- **Piston with counterweight** able to work with high intensity fluid
- Limited pressure drop. Only minimum back pressure is required for the hermetic seal
- **Valve material compatibility** (PVC-U) with water conveyance, drinking water and other food substances according to **current regulations**
- Can be maintained with the valve body installed