

RVOV-RVOT D 75 ÷ 110 - Sediment strainer DN 10:100

RVOV PVC-U rigid - RVOT PVC-U transparent.
 Sediment strainer with PVC-U backing ring, drilled PN10/16.

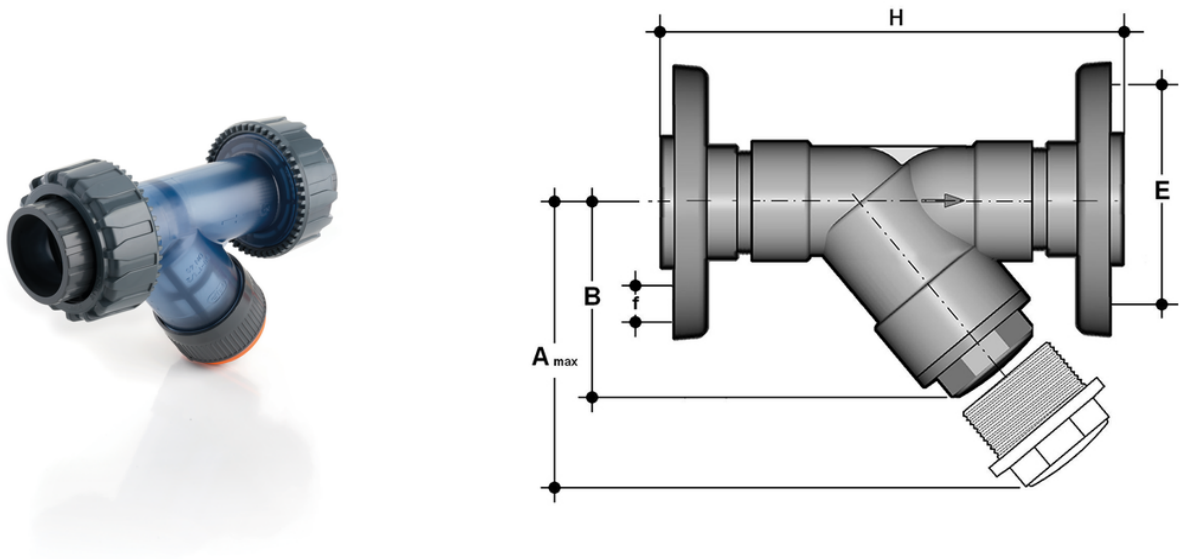

EPDM

Reference	tooltiplmage	system	Category	family	series	d	DN	PN RVOV	PN RVOT	A _{max}	B	F	f	H	Fig.	g
RVOV075E	-	PVC-U system	Manual valves	Auxiliary valves	RV DN 10÷100	75	65	10	6	300	179	145	17	356	B	3600
RVOV090E	-	PVC-U system	Manual valves	Auxiliary valves	RV DN 10÷100	90	80	6	4	325	192	160	17	404	B	4910
RVOV110E	-	PVC-U system	Manual valves	Auxiliary valves	RV DN 10÷100	110	100	6	4	385	231	180	17	475	C	6790
RVOT075E	-	PVC-U system	Manual valves	Auxiliary valves	RV DN 10÷100	75	65	10	6	300	179	145	17	356	B	3600
RVOT090E	-	PVC-U system	Manual valves	Auxiliary valves	RV DN 10÷100	90	80	6	4	325	192	160	17	404	B	4910
RVOT110E	-	PVC-U system	Manual valves	Auxiliary valves	RV DN 10÷100	110	100	6	4	385	231	180	17	475	C	6790



RVOV-RVOT D 75 ÷ 110 - Sediment strainer DN 10:100

- Connection system for solvent weld, threaded and flanged joints
- **Strainer** mounted on an easily removed **support** that facilitates the cleaning or replacement
- **Valve material compatibility** (PVC-U) with water conveyance, drinking water and other food substances according to **current regulations**
- Can be maintained with the valve body installed