

# VKROM/CE 24 V AC/DC 4-20 mA - Electrically actuated DUAL BLOCK® regulating ball valve DN 10:50

Electrically actuated DUAL BLOCK® regulating ball valve with DIN 2501 - EN 1092 fixed flanges, face to face according to EN 558-1 and modulating electric actuator 24 V AC/DC.

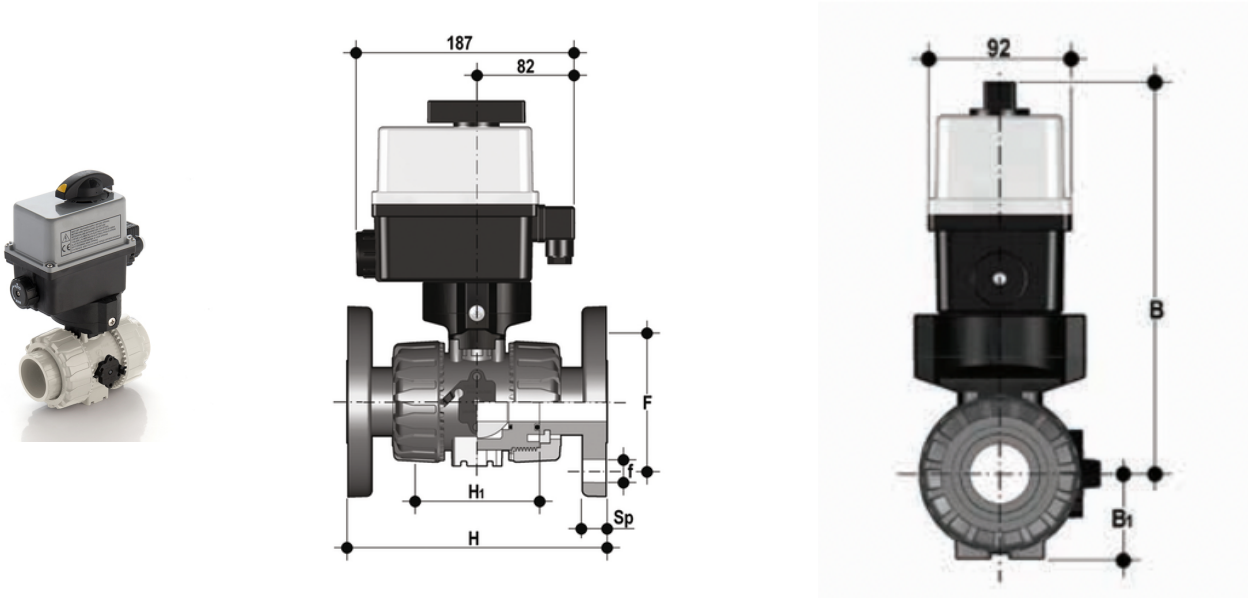

## EPDM

Reference	system	Category	family	series	d	DN	B	B <sub>1</sub>	PN	H	H <sub>1</sub>	F	f	U	Sp	g
VKROMEL020E0E	Automation system	Electrically actuated valves	Ball valves	VKR/CE DN 10÷50	20	15	205	29	10	130	65	65	14	4	11	1715
VKROMEL025E0E	Automation system	Electrically actuated valves	Ball valves	VKR/CE DN 10÷50	25	20	216	34.5	10	150	70	75	14	4	14	1791
VKROMEL032E0E	Automation system	Electrically actuated valves	Ball valves	VKR/CE DN 10÷50	32	25	221	39	10	160	78	85	14	4	14	1871
VKROMEL040E0E	Automation system	Electrically actuated valves	Ball valves	VKR/CE DN 10÷50	40	32	238	46	10	180	88	100	18	4	14	2156
VKROMEL050E0E	Automation system	Electrically actuated valves	Ball valves	VKR/CE DN 10÷50	50	40	244	52	10	200	93	110	18	4	16	2358
VKROMEL063E0E	Automation system	Electrically actuated valves	Ball valves	VKR/CE DN 10÷50	63	50	261	62	10	230	111	125	18	4	16	2807

## FKM

Reference	system	Category	family	series	d	DN	B	B <sub>1</sub>	PN	H	H <sub>1</sub>	F	f	U	Sp	g
VKROMEL020F0E	Automation system	Electrically actuated valves	Ball valves	VKR/CE DN 10÷50	20	15	205	29	10	130	65	65	14	4	11	1715
VKROMEL025F0E	Automation system	Electrically actuated valves	Ball valves	VKR/CE DN 10÷50	25	20	216	34.5	10	150	70	75	14	4	14	1791



# VKROM/CE 24 V AC/DC 4-20 mA - Electrically actuated DUAL BLOCK® regulating ball valve DN 10:50

Reference	system	Category	family	series	d	DN	B	B <sub>1</sub>	PN	H	H <sub>1</sub>	F	f	U	Sp	g
VKROMEL032FOE	Automation system	Electrically actuated valves	Ball valves	VKR/CE DN 10÷50	32	25	221	39	10	160	78	85	14	4	14	1871
VKROMEL040FOE	Automation system	Electrically actuated valves	Ball valves	VKR/CE DN 10÷50	40	32	238	46	10	180	88	100	18	4	14	2156
VKROMEL050FOE	Automation system	Electrically actuated valves	Ball valves	VKR/CE DN 10÷50	50	40	244	52	10	200	93	110	18	4	16	2358
VKROMEL063FOE	Automation system	Electrically actuated valves	Ball valves	VKR/CE DN 10÷50	63	50	261	62	10	230	111	125	18	4	16	2807



# VKROM/CE 24 V AC/DC 4-20 mA - Electrically actuated DUAL BLOCK® regulating ball valve DN 10:50

In addition to the manually actuated version, VKR is also available in electrically actuated VKR/CE configuration. Actuators are firmly connected to the valve by the special FIP PowerQuick modules fully made of PP-GR technopolymer. VKR/CE are constructed with actuators meeting current regulations and selected by FIP according to their quality and reliability requirements. The efficiency of these valves, tested according to the company's quality standards, is guaranteed by the expertise and know-how that FIP dedicates to manufacturing its products.

- Electric modulating actuator constructed according to FIP specifications; with plastic shell and standard emergency override. Available with voltages from 12 to 240V with 4-20mA and 0-10 V input
- High surface finish stem with double O-Ring. The double connection key system guarantees solid and reliable actuator torque transmission to the ball
- Easy to install PowerQuick module for pneumatic or electric actuator fully made of highly robust technopolymer
- The patented ball design provides linear flow regulation throughout its range of operation even when the valve is open just a few degrees and guarantees minimum pressure drops
- Patented DUAL BLOCK® system: prevents union nuts from loosening even under extreme operating conditions: e.g. vibration or thermal expansion
- Joint system for solvent welding (PVC-U only), for welding (PP-H and PVDF only), for threading and flanging
- Patented SEAT STOP® ball carrier system that lets you micro-adjust ball seats and minimise the axial force effect.
- Easy radial disassembly allowing quick replacement of O-rings and ball seats without any need for tools
- Radial dismounting valve body (True Union) made for PVC-U, PVC-C and PVDF-H injection moulding equipped with built-in bores for actuation. ISO 9393 compliant test requisites
- Option of disassembling downstream pipes with the valve in the closed position
- High surface finish stem with double O-Ring and double groove ball connection
- Integrated bracket for valve anchoring
- Ball seat carrier can be adjusted using the Easytorque adjustment kit
- Actuation option: version with electric modulating actuator with 4-20 mA / 0-10 V inlet and 4-20 mA / 0-10 V outlet to monitor the position
- Valve suitable for carrying fluids that are clean and free of suspended particles