

# VKDNC/CP NC - Pneumatically actuated DUAL BLOCK® 2-way ball valve DN 10:50

Pneumatically actuated DUAL BLOCK® ball valve with NPT socket threaded ends, Normally Closed.

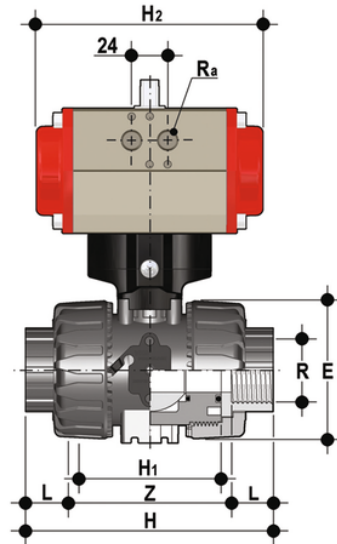
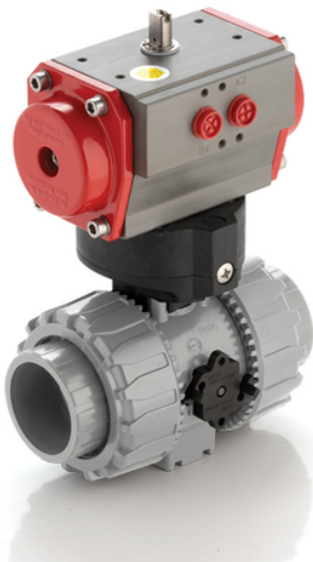

## EPDM

Reference	tooltipImage	system	Category	family	series	R	DN	PN	E	H	H1	L	Z	H2	R <sub>a</sub>	B	B <sub>1</sub>	E <sub>1</sub>
VKDNCNC038E	-	Automation system	Pneumatically actuated valves	Ball valves	VKD/CP DN 10÷50	3/8"	10	16	54	103	65	13,7	75,6	160	G1/8"	135	29	60.5
VKDNCNC012E	-	Automation system	Pneumatically actuated valves	Ball valves	VKD/CP DN 10÷50	1/2"	15	16	54	111	65	17,8	75,4	160	G1/8"	135	29	60.5
VKDNCNC034E	-	Automation system	Pneumatically actuated valves	Ball valves	VKD/CP DN 10÷50	3/4"	20	16	65	117	70	18	81	138	G1/8"	156.5	34.5	75
VKDNCNC100E	-	Automation system	Pneumatically actuated valves	Ball valves	VKD/CP DN 10÷50	1"	25	16	73	135	78	22,6	89,8	138	G1/8"	161	39	75
VKDNCNC114E	-	Automation system	Pneumatically actuated valves	Ball valves	VKD/CP DN 10÷50	1" 1/4	32	16	86	153	88	25,1	102,8	155.5	G1/4"	194	46	86
VKDNCNC112E	-	Automation system	Pneumatically actuated valves	Ball valves	VKD/CP DN 10÷50	1" 1/2	40	16	98	156	93	24,7	106,6	155.5	G1/4"	200	52	86

# VKDNC/CP NC - Pneumatically actuated DUAL BLOCK® 2-way ball valve DN 10:50

Reference	tooltiplmage	system	Category	family	series	R	DN	PN	E	H	H1	L	Z	H2	R <sub>G</sub>	B	B <sub>1</sub>	E <sub>1</sub>
VKDNCNC200E	-	Automation system	Pneumatically actuated valves	Ball valves	VKD/CP DN 10÷50	2"	50	16	122	186	111	29,6	126,8	155,5	G1/4"	217	62	86

## FKM

Reference	tooltiplmage	system	Category	family	series	R	DN	PN	E	H	H1	L	Z	H2	R <sub>G</sub>	B	B <sub>1</sub>	E <sub>1</sub>
VKDNCNC038F	-	Automation system	Pneumatically actuated valves	Ball valves	VKD/CP DN 10÷50	3/8"	10	16	54	103	65	13,7	75,6	160	G1/8"	135	29	60,5
VKDNCNC012F	-	Automation system	Pneumatically actuated valves	Ball valves	VKD/CP DN 10÷50	1/2"	15	16	54	111	65	17,8	75,4	160	G1/8"	135	29	60,5
VKDNCNC034F	-	Automation system	Pneumatically actuated valves	Ball valves	VKD/CP DN 10÷50	3/4"	20	16	65	117	70	18	81	138	G1/8"	156,5	34,5	75
VKDNCNC100F	-	Automation system	Pneumatically actuated valves	Ball valves	VKD/CP DN 10÷50	1"	25	16	73	135	78	22,6	89,8	138	G1/8"	161	39	75
VKDNCNC114F	-	Automation system	Pneumatically actuated valves	Ball valves	VKD/CP DN 10÷50	1" 1/4	32	16	86	153	88	25,1	102,8	155,5	G1/4"	194	46	86
VKDNCNC112F	-	Automation system	Pneumatically actuated valves	Ball valves	VKD/CP DN 10÷50	1" 1/2	40	16	98	156	93	24,7	106,6	155,5	G1/4"	200	52	86
VKDNCNC200F	-	Automation system	Pneumatically actuated valves	Ball valves	VKD/CP DN 10÷50	2"	50	16	122	186	111	29,6	126,8	155,5	G1/4"	217	62	86

# VKDNC/CP NC – Pneumatically actuated DUAL BLOCK® 2-way ball valve DN 10:50

In addition to the manually actuated version, VKD is also available in VKD/CE electrically actuated and VKD/CP pneumatically actuated configurations. Actuators are firmly connected to the valve by the special FIP PowerQuick modules fully made of PP-GR technopolymer. VKD/CE and VKD/CP are constructed with actuators meeting current regulations and selected by FIP according to their quality and reliability requirements. The efficiency of these valves, tested according to the company's quality standards, is guaranteed by the expertise and know-how that FIP dedicates to manufacturing its products.

- Electric actuator constructed according to FIP specifications; with plastic shell and standard emergency override. Available with voltages from 12 to 240V
- Rack & pinion type pneumatic actuator constructed according to FIP specifications: fully protected against weather corrosion available in double-acting (DA) or simple-acting normally closed (NC) or normally open (NO) versions
- DUAL BLOCK® patented lock system that ensures union nut tightening hold even in severe conditions such as vibrations or heat dilation
- Double stem with double O-Rings for ball centring and operating torque reduction. The upper stem is also equipped with a co-moulded steel insert that guarantees high durability and perfect torque transmission between the actuator and ball
- Joint system for solvent welding (PVC-U and PVC-C only), for welding (PP-H and PVDF only), for threading and flanging
- Patented SEAT STOP® ball carrier system that lets you micro-adjust ball seats and minimise the axial force effect
- Easy radial disassembly allowing quick replacement of O-rings and ball seats without any need for tools
- Radial dismounting valve body (True Union) made for PVC-U, PVC-C and PP-H injection moulding equipped with built-in bores for actuation. ISO 9393 compliant test requisites
- Option of disassembling downstream pipes with the valve in the closed position
- Floating full bore ball with high surface finish
- Integrated bracket for valve anchoring
- Possibility of installing a gear box or pneumatic and/or electric actuators by applying an ISO standard bore PP-GR flange
- Stainless steel co-moulded stem, with square section as per ISO 5211