

# LKDAV/CE 24 V AC/DC - Electrically actuated DUAL BLOCK® 3-way ball valve DN 10:50

3 way DUAL BLOCK® ball valve with female ends, ASTM series with electric actuator 24 V AC/DC "L" ball.

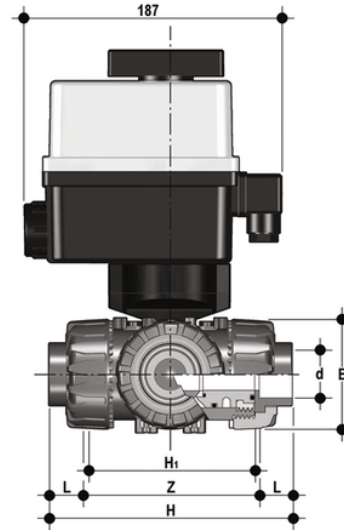

## EPDM

Reference	tooltiplage	system	Category	family	series	d	DN	PN	E	H	H1	L	Z	B	B <sub>1</sub>	g
LKDAVEL038E1	-	Automation system	Electrically actuated valves	Ball valves	TKD/CE DN 10÷50	3/8"	10	16	54	132.19999999999999	80	19,5	93.2	205	29	1843
LKDAVEL012E1	-	Automation system	Electrically actuated valves	Ball valves	TKD/CE DN 10÷50	1/2"	15	16	54	132.19999999999999	80	23	87.2	205	29	1843
LKDAVEL034E1	-	Automation system	Electrically actuated valves	Ball valves	TKD/CE DN 10÷50	3/4"	20	16	65	159.19999999999999	100	25,5	108.2	216	34.5	2076
LKDAVEL100E1	-	Automation system	Electrically actuated valves	Ball valves	TKD/CE DN 10÷50	1"	25	16	73	174	110	28,7	116.6	221	39	2299
LKDAVEL114E1	-	Automation system	Electrically actuated valves	Ball valves	TKD/CE DN 10÷50	1" 1/4	32	16	86	205	131	32	141	238	46	2880
LKDAVEL112E1	-	Automation system	Electrically actuated valves	Ball valves	TKD/CE DN 10÷50	1" 1/2	40	16	98	227.6	148	35	157.6	244	52	3242



# LKDAV/CE 24 V AC/DC - Electrically actuated DUAL BLOCK® 3-way ball valve DN 10:50

Reference	tooltiplmage	system	Category	family	series	d	DN	PN	E	H	H1	L	Z	B	B <sub>1</sub>	g
LKDAVEL200E1	-	Automation system	Electrically actuated valves	Ball valves	TKD/CE DN 10÷50	2"	50	*10	122	267	179	38,2	190.6	261	62	4362

## FKM

Reference	tooltiplmage	system	Category	family	series	d	DN	PN	E	H	H1	L	Z	B	B <sub>1</sub>	g
LKDAVEL038F1	-	Automation system	Electrically actuated valves	Ball valves	TKD/CE DN 10÷50	3/8"	10	16	54	132.19999999999999	80	19,5	93.2	205	29	1843
LKDAVEL012F1	-	Automation system	Electrically actuated valves	Ball valves	TKD/CE DN 10÷50	1/2"	15	16	54	132.19999999999999	80	23	87.2	205	29	1843
LKDAVEL034F1	-	Automation system	Electrically actuated valves	Ball valves	TKD/CE DN 10÷50	3/4"	20	16	65	159.19999999999999	100	25,5	108.2	216	34.5	2076
LKDAVEL100F1	-	Automation system	Electrically actuated valves	Ball valves	TKD/CE DN 10÷50	1"	25	16	73	174	110	28,7	116.6	221	39	2299
LKDAVEL114F1	-	Automation system	Electrically actuated valves	Ball valves	TKD/CE DN 10÷50	1" 1/4	32	16	86	205	131	32	141	238	46	2880
LKDAVEL112F1	-	Automation system	Electrically actuated valves	Ball valves	TKD/CE DN 10÷50	1" 1/2	40	16	98	227.6	148	35	157.6	244	52	3242
LKDAVEL200F1	-	Automation system	Electrically actuated valves	Ball valves	TKD/CE DN 10÷50	2"	50	*10	122	267	179	38,2	190.6	261	62	4362

# LKDAV/CE 24 V AC/DC – Electrically actuated DUAL BLOCK® 3-way ball valve DN 10:50

In addition to the manually actuated version, TKD is also available in TKD/CE electrically actuated and TKD/CP pneumatically actuated configurations. Actuators are firmly connected to the valve by the special FIP Power Quick modules fully made of PP-GR technopolymer. TKD/CE and TKD/CP are constructed with actuators meeting current regulations and selected by FIP according to their quality and reliability requirements. The efficiency of these valves, tested according to the company's quality standards, is guaranteed by the expertise and know-how that FIP dedicates to manufacturing its products.

- Electric actuator constructed according to FIP specifications; with plastic shell and standard emergency override. Available with voltages from 12 to 240V.
- Rack & pinion type pneumatic actuator constructed according to FIP specifications: fully protected against weather corrosion available in double-acting (DA) or simple-acting normally closed (NC) or normally open (NO) versions. Three different positions according to 2 configurations are possible with T ball: 0°-90°-180° and 0°-90°-270°.
- High surface finish stem with double O-Ring. The double connection key system guarantees solid and reliable actuator torque transmission to the ball.
- Easy to install PowerQuick module for pneumatic or electric actuator fully made of highly robust technopolymer.
- DUAL BLOCK® patented lock system that ensures union nut tightening hold even in severe conditions such as vibrations or heat dilation.
- Ball shutter high surface finish with floating type full passage with T or L port.
- Joint system for solvent welding (PVC-U and PVC-C only), for welding (PP-H only), for threading
- Patented SEAT STOP® ball seat carrier system that lets you micro-adjust ball seats and minimise axial force effects
- Easy radial disassembly allowing quick replacement of O-rings and ball seats without any need for tools
- Radial dismounting valve body (True Union) made for PVC-U, PVC-C and PP-H injection moulding equipped with built-in bores for actuation. ISO 9393 compliant test requisites
- Option of disassembling downstream pipes with the valve in the closed position
- High surface finish stem with double O-Ring and double connection key to the ball, equipped with visual ball position indicator for correct handle installation
- Integrated bracket for valve anchoring
- Possibility of installing pneumatic and/or electric actuators thanks to the robust anchor tower for easy and quick automation using the Power Quick module.